

Improvement of Voltage Profile in Hybrid PV-Wind System using STATCOM

Jella Ramakrishna ^a, K. Rakesh ^b and Dr. T. Anil Kumar ^c

^a PG Student Department of Electrical and Electronics Engineering, Anurag Group of Institutions (now Anurag University

^{b,c} Assistant Professor Department of Electrical and Electronics Engineering, Anurag University, Venkatapur, Ghatkesar, Medchal-Malkajgiri District, Hyderabad, Telangana, India. 500088

email: ^aramakrishnajella241@gmail.com, ^brakesheee@cvsr.ac.in, ^cthalluruani@gmail.com

Article History: Received: 11 January 2021; Revised: 12 February 2021; Accepted: 27 March 2021; Published online: 23 May 2021

Abstract: With multiple renewable sources connected to the grid, different voltage profile problems are introduced which include voltage sags and fluctuations. These problems are solved by different FACTS devices connected at PCC improving the voltage profile. This paper discusses the STATCOM module integrated into a grid with a FIS structure in the controller for better results as compared to conventional controllers. The distribution grid considered for the analysis comprises of PVA module and PMSG wind farm as renewable energy resources connected at PCC in parallel to the main grid and STATCOM. The analysis is carried out on the proposed distribution test system with different operating conditions using MATLAB software Simulink block sets. All comparison graphs are generated using 'powergui' toolbox with time domain analysis.

Keywords: FACTS (Flexible alternating current transmission system), PCC (Point of Common Coupling), STATCOM (Static Synchronous Compensator), FIS (Fuzzy Interface Structure), PVA (Photo Voltaic Array), PMSG (Permanent Magnet Synchronous Generator), MATLAB, Powergui.

1. Introduction

In the new age, electrical power systems, multiple renewable energy sources [1] are connected at the distribution level for power sharing reducing power consumption from the main grid. To reduce power loss from the renewable sources the modules are connected near to loads reducing power transfer from long distances. The renewable energy sources (RES) integrated into the distribution grid is PVA and PMSG wind farm [2] controlled by power electronic converters [3]. As the power generated from renewable sources is uncertain because of the unpredictable solar irradiation (for PVA) and wind speeds (for a wind farm) of the environment, multiple voltage profile issues are created which include voltage sags, fluctuations, harmonics, power factor drop in main grid. These issues need to be solved for a better grid system maintaining the voltage profile at PCC reducing damage to the devices and loads connected to the grid. These issues are solved by integrating the FACTS device [9] into the grid, improving voltage magnitude, reducing harmonics, improving the power factor of the main grid source. All these issues are solved by connecting a STATCOM [9] at PCC which injects reactive power into the distribution grid compensating power of the load, stabilizing voltage magnitude at PCC, reducing harmonics. A STATCOM is a power electronic module that comprises controllable IGBTs along with a static capacitor on the DC side. The control of these power electronic switches in the module controls the reactive power injection to the grid. The proposed distribution test system with RES and STATCOM modules connected to the main grid and loads can be observed below in figure 1.

As it can be observed the PVA source [4] is connected with a boost converter for stabilizing the DC output voltage of the PVA module. The boost converter is controlled by the MPPT algorithm with duty ratio control. The wind farm module comprises of wind turbine for mechanical power generation and PMSG for converting mechanical power to electrical power. These RES modules are connected to the grid through a high power coupling transformer. Multiple rating loads are connected for different operating conditions on the grid and STATCOM connected for reactive power injection.

In this paper, section I is included with an introduction of the proposed system followed by section II which includes operating principles of RES modules. Section III has STATCOM working principle and control structure modeling. Results and analysis of the introduced modules with different operating conditions by changing loads on the grid is observed in section IV. All the

Fig. 1: Proposed distribution test system with RES and STATCOM modules

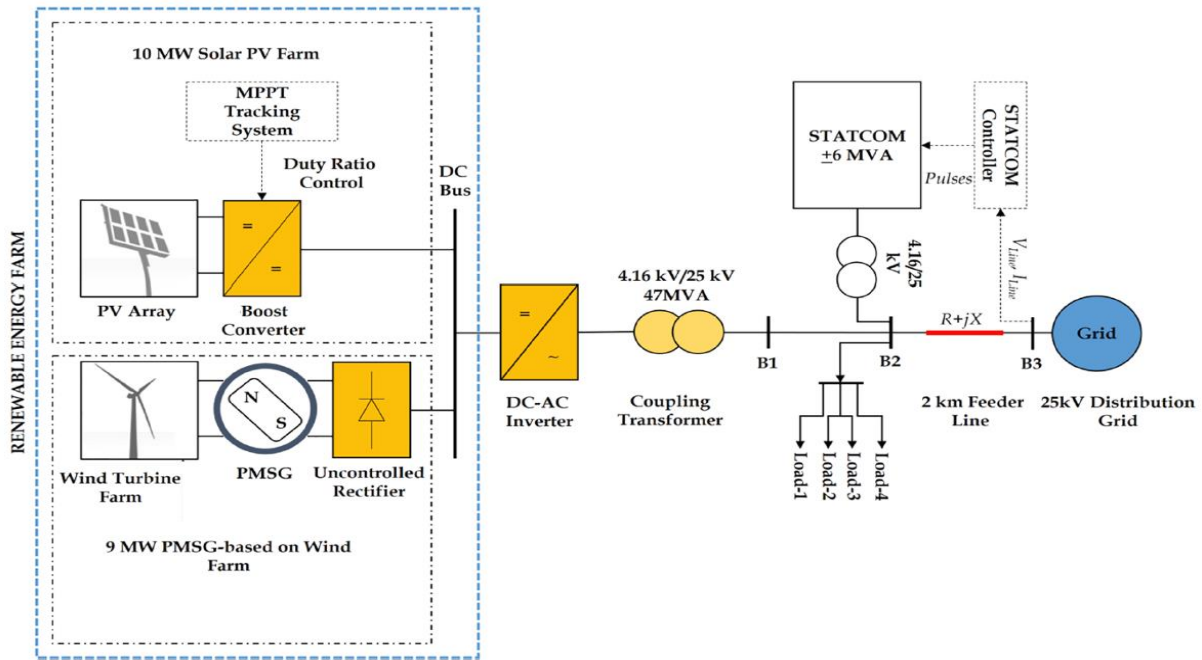

comparable graphical representations are presented in this section IV followed by section V which includes the conclusion and references used for this paper.

2.Res Modules Modeling

There are many renewable sources developed in electrical power engineering by utilization of natural resources for the generation of electrical power. The RES modules that can be used are PVA, wind farm, fuel cell, tidal energy farms, biogas plants, etc. Apart from all these sources, PVA and wind farm RES modules are considered to be optimal options for the generation of power from renewable natural sources. These modules have less installation and less maintenance cost and hence are adopted into our proposed distribution test system. The internal modeling of PVA along with boost converter [6] topology can be seen in the figure below.

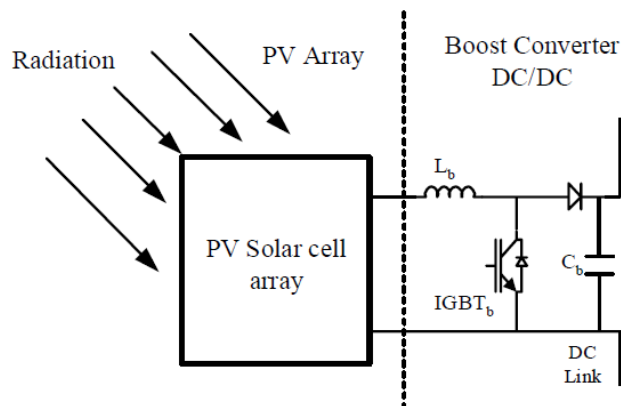

Fig. 2: PVA module with a boost converter

The input is a PVA source connected to a boost converter for DC voltage stabilization in the circuit above. The duty ratio of the switch S, which is created by the MPPT algorithm using feedback from the PVA voltage and current, is used to regulate the DC voltage output V_o . The P&O (Perturb and Observe) method [8] was used as the MPPT algorithm for the above converter, as shown in figure 3.

The above machine parameters are of 3MW machine operated by wind turbine connected to the machine controlling the input mechanical torque to the generator [7] concerning wind speed. The parameters of a wind turbine are given in table III.

Table Iii

Name of parameter	Value
Nominal mechanical power	3MW
Electrical power	3.33MV A
Rated wind speed	12mt/sec
Power output at rated wind speed	0.8pu
Rated shaft speed	1pu
Pitch angle	0deg

With the above parameters of PMSG and wind turbine, the wind farm is modeled with three modules connected in parallel with total generation power of $3 \times 3\text{MW} = 9\text{MW}$. Both the PVA and PMSG wind farm are connected in parallel to a three-phase inverter which converts DC power to three-phase AC power which can be utilized by the loads or interconnected to a three-phase grid [7] for power sharing. For grid interconnection, a three-phase voltage synchronization is needed for sharing of power from RES. The inverter is controlled by the three-phase sinusoidal PWM technique.

3.Statcom Modeling

To compensate for inductive reactive load power consumption from conventional or renewable sources, a STATCOM [9] FACTs system is used to inject reactive power into the grid. This compensation of reactive power of load improves the performance of the grid by increasing the power factor of the sources near to unity. This also improves the voltage magnitude at PCC where all the modules are connected maintaining the value between 0.95pu and 1.05pu. However, along with reactive power compensation [10], the STATCOM also stabilizes the voltage at PCC with very low ripple and harmonics in the three-phase voltages. The power device takes feedback from PCC voltages and conventional source currents for the required reactive power compensation. Figure 4 shows the internal structure of the power electronic device integrated STATCOM device.

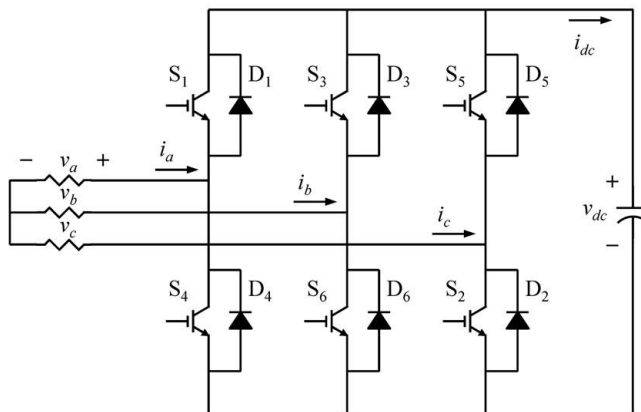

Fig. 4: STATCOM circuit topology

The device comprises six power electronic switches which can be either IGBT or MOSFET controlled by PWM pulses. On the DC side, a high rating capacitance [10] is connected for the generation of reactive power by consuming leading current from the grid. The magnitude of consuming leading current is set by a feedback control system with synchronization of PCC [11] three-phase voltages (where the STATCOM is interconnected). The proposed control structure for the reactive power compensation device is represented in figure 5.

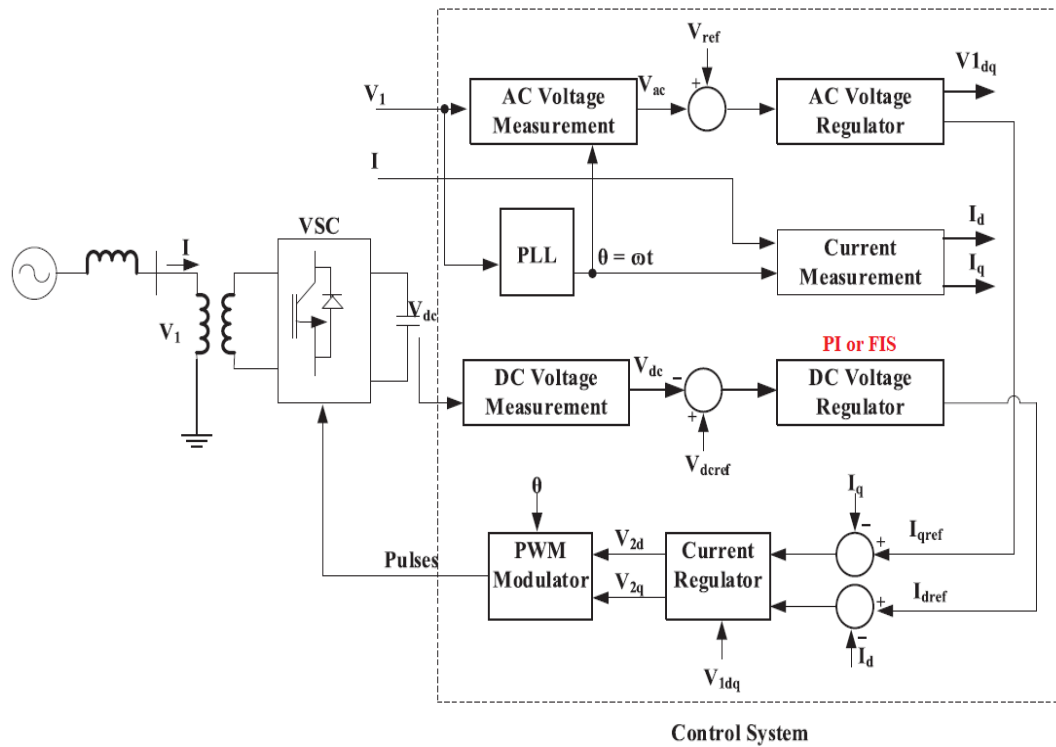

Fig. 5: STATCOM control structure

In the above control structure, there are two sub modules, which include the AC part and DC part. The AC part takes feedback from the PCC voltages (V_1), and load currents (I) [12]. The dq components are generated by parks transformation operated by PLL in synchronization with V_1 . For STATCOM current reference (I_{dref} and I_{qref}), the d-axis component is considered from the DC voltage regulator [12] which is the DC part. The reference d-axis component is generated by a comparison of reference DC voltage value to measured DC voltage across the DC side capacitor [13]. The error is fed to the PI controller or fuzzy interface system (FIS) [14] for the generation of the d-component. The q-axis current component is produced by the AC voltage regulator by comparison of reference voltage magnitude to measured PCC voltage magnitude. The final reference signals for the PWM pulse generation are generated by the current regulator by comparison of reference current components (I_{dref} and I_{qref}) to measured current components (I_d I_q). The DC voltage regulator fuzzy interface system [14] with two input membership functions and one output membership function is given in figure 6.

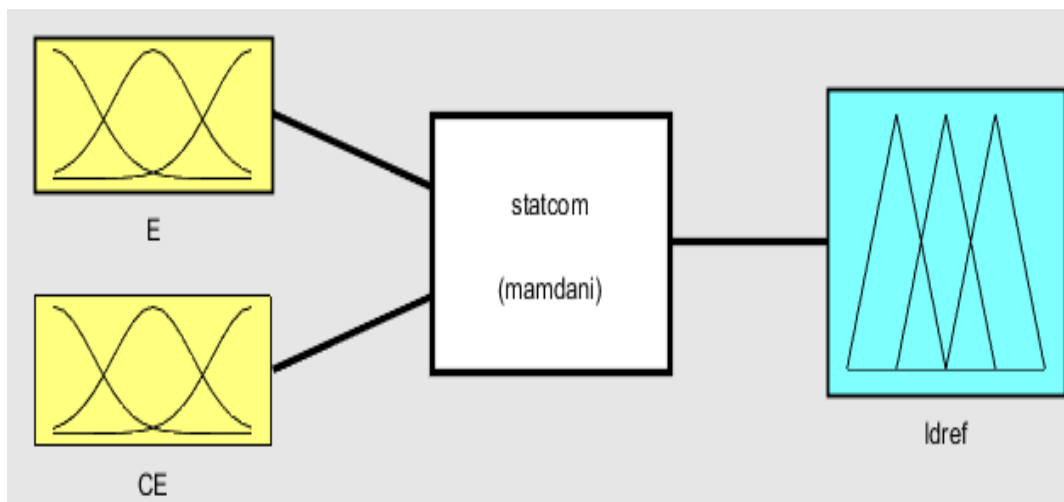

Fig. 6: Fuzzy interface structure for DC voltage regulator

The Mamdani system of the FIS has 49 rule base with seven membership functions set for the generation of output reference d-axis current component. The rule base for the proposed FIS is given in table IV.

Table IV

		← e →						
		NB	NM	NS	EZ	PS	PM	PB
de	↑	PB	Z	PS	PM	PB	PB	PB
	PM	NS	Z	PS	PM	PB	PB	PB
	PS	NM	NS	Z	PS	PM	PB	PB
	EZ	NB	NM	NS	Z	PS	PM	PB
	NS	NB	NB	NM	NS	Z	PS	PM
	↓	NM	NB	NB	NM	NS	Z	PS
	NB	NB	NB	NB	NB	NM	NS	Z

As per the rule base, 'e' variable represents the error value (produced by comparison of DCref and DCmeas) and 'de' variable represents a change in error value (produced by comparison of e(i) and e(i-1)). Here e(i) is the present error value and e(i-1) is the past error value which is generated by unit delay.

4.Simulink Results And Discussion

For analysis of power transfers from each module and voltage magnitude at PCC, simulations are run on four different test systems using the above modules. The results are compared for these proposed test systems and the optimal system is decided. The below are the possible test systems for given modules.

- a) Test system 1- Only renewable sources PVA and wind farm feeding variable load
- b) Test system 2- Conventional source grid with the renewable source connected in parallel
- c) Test system 3- Grid along with renewable sources and STATCOM (PI controller)
- d) Test system 4- Grid along with renewable sources and STATCOM (FIS controller)

In all the above test systems same load variations are taken at different instants of time with different active and reactive power consumptions. The variable load ratings for 8sec simulation time are given below.

Loading Condition	Load Number	Type	Rating
Loading-A	Load-1	Resistive	2 MW
	Load-2	Resistive	10 MW
Loading-B	Load-1	Resistive	2 MW
	Load-2	Resistive	10 MW
	Load-3	Resistive	8 MW
	Load-4	Inductive	10 MVAR
Loading-C	Load-1	Resistive	2 MW

Loading-A is applied between time 0-3sec, 4-5sec and 6-8sec, Loading-B is applied between 3-4sec, Loading-C is applied between 5-6sec. The graphical representation of the powers and voltages at PCC for different test systems for the given load variations are shown below.

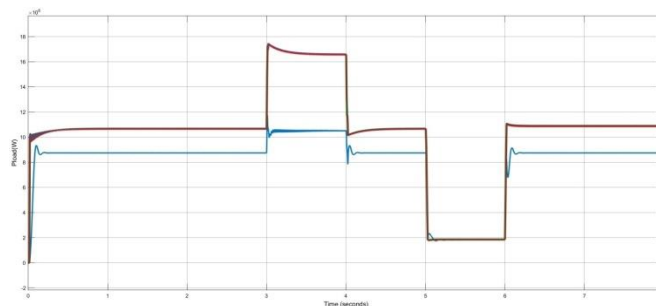

Fig. 7: Active power of load of 4 test systems

The above are the active powers of the time variable load as per the loading given above. The graph comprises of comparison of active power for all four cases.

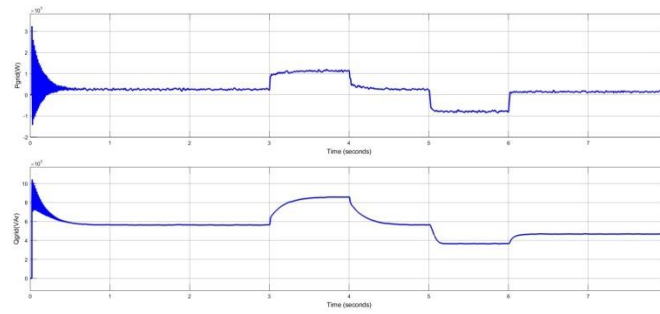

Fig. 8: Grid active and reactive powers for case 4

Results of test system 4 are considered as it is considered as the optimal operating system with renewable sources, grid, STATCOM operated by the fuzzy controller. The above are the grid active and reactive power exchange as per loading conditions. The below is the load active and reactive power graph.

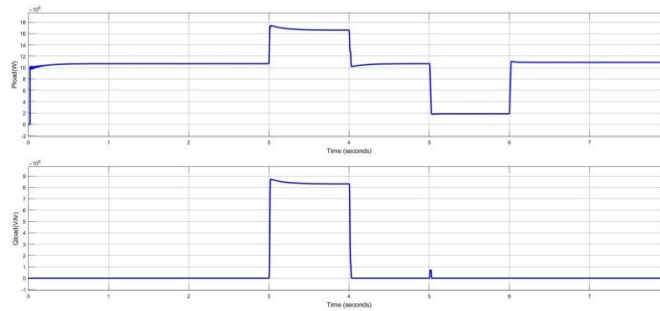

Fig. 9: Load active and reactive powers for case 4

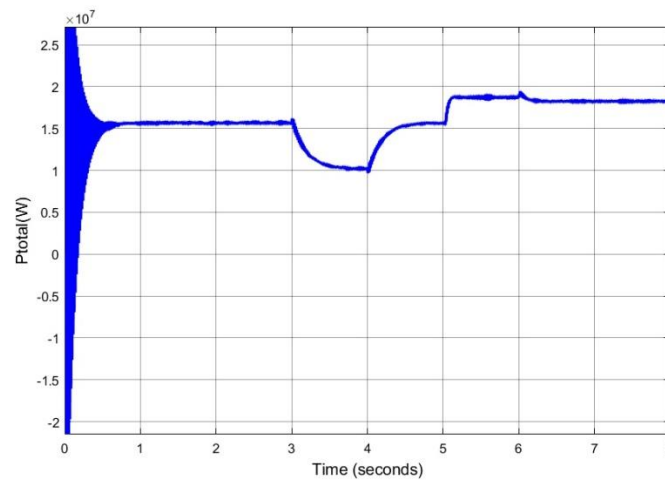

Fig. 10: Total active power injection from renewable sources

The above is the total active power injected by the renewable source recorded at a maximum of 20MW and minimum at 10MW as per changes in solar irradiation and wind speeds. The below is the graph of fuzzy controlled STATCOM injected reactive power recorded at 6MVAR supporting the load reactive power consumption.

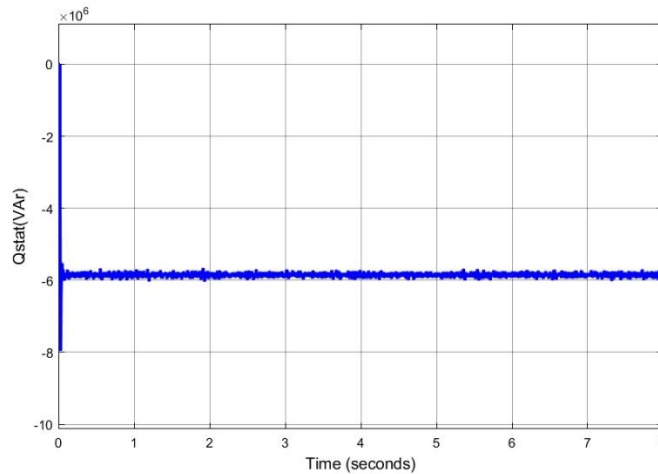

Fig. 11: Reactive power injection from STATCOM with FIS controller

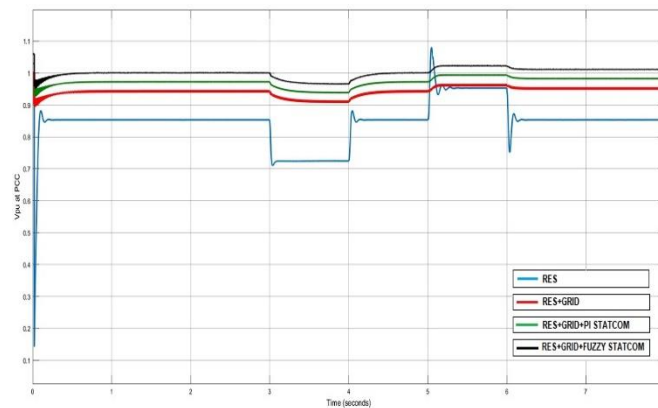

Fig. 12: PCC voltage magnitudes of 4 test systems

The above graph is the comparison of voltage magnitudes at PCC per unit for all four test systems. As seen in the comparison the fourth test system with fuzzy STATCOM connected to the grid has a more stable voltage magnitude and is maintained in the given limit between 0.95pu and 1.05pu as per IEEE standards.

5. Conclusion

In the above results, the voltage magnitude at PCC for test system 4 is maintained between 0.95pu and 1.05pu which is in the allowable range. This is achieved when the test system with renewable sources and grid is connected along with STATCOM at PCC with a FIS controller. The fuzzy controller connected at the DC voltage regulator improves the d-component with optimal value for maintaining the voltage in the given range. The powers of the loads are however maintained the same in all cases and the power injection from renewable sources and grid is also the same. A comparative analysis with different operating conditions and different controllers are shown proving that the system is more stable when operated with STATCOM controlled by the FIS control structure.

References

1. Choi, Hang-Seok, et al. "Grid-Connected Photovoltaic Inverter with Zero-Current-Switching." Proceedings of the KIPE Conference. The Korean Institute of Power Electronics, 2001.
2. Rosas, Pedro. "Dynamic influences of wind power on the power system." (2003).
3. Manel, Juan. "Power electronic system for grid integration of renewable energy source: A survey." IEEE Trans. Ind. Electron 53.4 (2006): 1002-1014.
4. El-Tamaly, H. H., Ali M. El-Tamaly, and A. A. El-Baset Mohammed. "Design and control strategy of utility interfaced PV/WTG hybrid system." The ninth international middle east power system conference, MEPCON. 2003.
5. Johnsen, Kim. "SIMULINK implementation of wind farm model for use in power system studies." Nordic Wind Power Conference 2004. 2004.

6. Lew, Debra J., C. Dennis Barley, and Lawrence T. Flowers. "Hybrid wind/photovoltaic systems for households in inner Mongolia." international conference on village electrification through renewable energy, New Delhi. 1997.
7. El-Tamaly, H. H., and AAE-B. Mohammed. "Computer modeling and simulation of wind energy system connected to utility grid." International Conference on Electrical, Electronic and Computer Engineering, 2004. ICEEC'04.. IEEE, 2004.
8. Barbosa, Pedro G., et al. "Novel control strategy for grid-connected DC-AC converters with load power factor and MPPT control." (1995).
9. Han, Chong, et al. "STATCOM impact study on the integration of a large wind farm into a weak loop power system." IEEE Transactions on Energy conversion 23.1 (2008): 226-233.
10. Tayyebifar, Touraj, Mohammad Shaker, and Majid Aghababaie. "Performance comparison of STATCOM versus SVC to improve reactive power control in wind power based DFIG under short circuit fault." 2014 Ninth International Conference on Ecological Vehicles and Renewable Energies (EVER). IEEE, 2014.
11. Sharma, Pawan, T. S. Bhatti, and K. S. S. Ramakrishna. "Study of an isolated wind–diesel hybrid power system with STATCOM by incorporating a new mathematical model of PMIG." European Transactions on Electrical Power 22.3 (2012): 351-363.
12. Wessels, Christian, Friedrich W. Fuchs, and Marta Molinas. "Voltage control of a statcom at a fixed speed wind farm under unbalanced grid faults." IECON 2011-37th Annual Conference of the IEEE Industrial Electronics Society. IEEE, 2011.
13. Wang, Keyou, and Mariesa L. Crow. "Power system voltage regulation via STATCOM internal nonlinear control." IEEE transactions on Power systems 26.3 (2010): 1252-1262.
14. Luo, An, et al. "Fuzzy-PI-based direct-output-voltage control strategy for the STATCOM used in utility distribution systems." IEEE Transactions on Industrial Electronics 56.7 (2009): 2401-2411.