

Women and Children Safety System with IOT

S.RahmathNisha^a, Dr.C.Shyamala^b, Dr.D.Sheela^c, M.Abirami^d, M.Harshini^e and R.Keerthana^f

^a Assistant Professor, Department of Computer Science and Engineering,
K.Ramakrishnan College of Technology.Tamilnadu,India

^bAssociate Professor, Department of Computer Science and Engineering,
K.Ramakrishnan College of Technology.Tamilnadu,India

^cProfessor, Department of Electronics and Communication Engineering,
Saveetha School of Engineering, Saveetha Institute of Medical and Technical
Sciences,Saveetha University,Chennai,Tamilnadu,India

^{d, e, f}UG Student, Department of Computer Science and Engineering,
K.Ramakrishnan College of Technology.Tamilnadu,India

Article History: Received: 10 January 2021; Revised: 12 February 2021; Accepted: 27 March 2021; Published online: 16 April 2021

Abstract: Today, innovation is developing quickly and giving all fundamental and compelling answers for each prerequisite. Present days heaps of cases seen of missing Women. The Women are missing have ages between 14 to 17. Parents are stressed over Women. The paper clarifies about an android application which is utilized to follow the missing ladies. These days heaps of cell phone clients have an android telephones. The application works with the assistance of android portable. The android application depends on GPS and SMS administrations in Android portable. The GPS administration is utilized for following accurate area of Women. The GPS and GSM based frameworks are utilized to follow the area of Women. There are two different ways that can an application works. First is GPS based that is identified with the Location administrations and second is notice based which is identified with the Network administration. In the event that Location based administrations not working, the application utilizes Network based administrations which can have the option to send and get messages. ESP32 camera is used to take image of the harasser and it is also used to send live video recordings to the parent side. MQTT protocol is used for high latency and bandwidth strength. This protocol is used to send high volumes of sensor messages.

In this situation, our framework guarantees greatest security and guarantees live following for their children since parent stresses are certified. This undertaking proposed a model for ladies wellbeing through advanced mobile phones that gives the alternative to follow the area of their ladies just as in case of crisis ladies can send a snappy message and it's present area by means of BLYNK application. This proposed framework is approved by testing on the Android stage utilizing IoT.

Keywords: IoT, Blynk server, ESP32 Camera, MQTT protocol, GPRS, GSM module.

1. Introduction

"The Internet of Things (IoT) insinuates a game plan of interrelated, web related articles that can assemble and move data over a distant association without human mediation". The individual or business prospects are interminable.

IoT began as a specialty market for specialists and has developed into a colossal industry. However, with this development comes security weaknesses and contemplations that should be perceived by industry players if the innovation is to be saddled viably. Producers, retailers and huge organizations are largely discovering approaches to use IoT stages, joining the information that they gather with investigation and progressed revealing frameworks. To effectively plan where the IoT patterns are going, we need to perceive what the current moves are on the lookout for 2018 and what the most well-known applications for IoT gadgets are in various areas. This methodology will assist us with understanding what IoT selection could mean for the organizations and undertakings of things to come and how to keep their information and organizations secure.

On the computerized century where innovation arrives at kids hands, watchmen may stress over the impact of this exceptionally open world on their children's turn of events. They may stress over the adverse impact of this innovation on their instructive, passionate and social turns of events. To help beat a portion of these concerns, gatekeepers may have to make them control innovation to check and track their ladies use for the individual gadgets. As tablet gadgets are perhaps the most utilized advancements by ladies on our general public, watchmen should have some robotized advances to notice and direct the time and nature of their ladies' use for these tablets.

2 Existing System:

The absence of safety and wellbeing measures, the crime percentage. Some article have discussed and developed women security but it has less privacy to inform about the issue to our family and those may also include fake news about the incident [1] other security systems have alarm facility on them which may alert the harasser [2,5] some devices are applicable only if there is a smart phone [9]. In an article there is a system which releases gas that affects the victim and causes high risk [4]. Accuracy of defecting is also low [3] cost is not affordable by some

of them which is not applicable to everyone [7,10]. Data and User Confidentiality Privacy Preservation and load balancing in networks is used for secured transactions of women safety messages[11,14], Security is ensured by sensors such as temperature and pressure sensors[12]. Machine learning and data mining techniques are used to categorize people such as believable and unbelievable.[13].

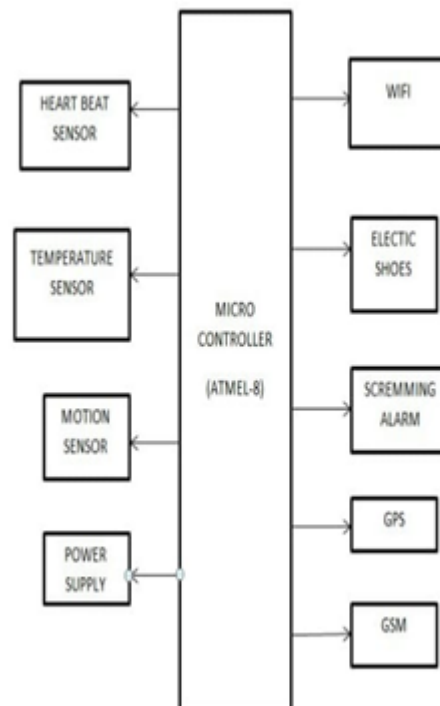

Fig-1: Block diagram

3 Proposed System:

The proposed framework "IoT Based Women and Woman Safety" can be accustomed to finding absent or lost ladies and furthermore following the ladies developments outside from the home. The framework can likewise be utilized to find ladies who are at serious risk. We have consolidated GPS with one of the essential assistance of an advanced cell which is GSM all the more explicitly SMS in a single framework. Our proposed model contains different sensors which measure various boundaries consistently. In case of emergency a message will be sent off gatekeepers just as police, by either pressing the sign for a crisis reaction or articulating the watchword. Every one of these tasks can be overseen and constrained by a versatile application introduced on the advanced mobile phones of concerned gatherings by means of the ongoing checking through the dashboard at the school organization. The general model augments security of understudies and assists with improving their general presentation. In our proposed framework we have utilized Android improvement IDE. For building up any application in android we require Java upheld Eclipse android IDE and client can choose the form of upheld OS according to its decision. Every one of the PDAs are Java stage based therefore to build up any application for PDAs we require Eclipse Android improvement IDE.

This paper configuration work for guardians and ladies. The guardians and ladies both have GPS Based advanced mobile phones. The application is utilized to follow the ladies area for execution of utilization, Android. The answer for following and missing women is done with the help of GPS and GSM innovations. There are two main administrations are utilized for this application that is GPS and SMS. For area administrations is GPS and communication services is SMS. By and large the chosen working framework is android to over every one of the highlights. SMS is utilized for conveying SDK devices and Eclipse which support android is utilized. Justification picking android OS is that to target more clients. Loads of individuals utilizing android portable phones. The application utilizes two fundamental administrations that is GPS and SMS. For area administrations is GPS and communication administrations is SMS. Generally chosen working framework is android to over all the features. SMS is utilized for imparting between ladies side and parent side. The System can be planned in a basic manner. The application created to make easy to understand approach on both sides. The application developed to make an easy to use approach on both sides require Java support obscure android IDE. The architecture of the

application is in light of customer worker design. First is parent side and another is ladies side. Parent side goes about as worker and women side goes about as a customer.

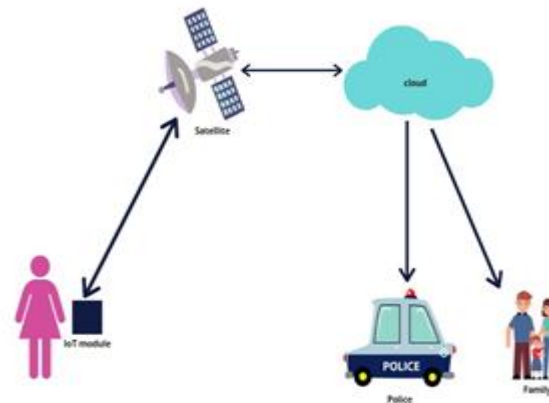

Fig-2

4 MODULE 1:

HARDWARE DESCRIPTION:

One approach to address the ladies wellbeing issues and increment the security and security utilizing detecting innovation and more associated through the supposed "IoT" otherwise called 'Savvy global positioning framework for ladies. The IOT passage at that point sends the information to the IoT stage (Cloud) utilizing the Wi-Fi module. The data set will keep up the information got from the IOT door.

Microcontroller gathering is the equipment part of the framework and oversees the information securing by means of the sensors present in it.

MODULE 2:

SYSTEM ARCHITECTURE:

The Network is mindful to proliferate the information to distributed storage, which examinations and performs estimations with sensor information got which is as crude information and displays it on the IoT interface. The organization between the Hardware parts to the cloud can be set up two, it is possible that it very well may be through MQTT specialists utilizing the MQTT convention, or through HTTP.

IoT BASED INTERFACE:

IoT reconciliation is worried about APIs, the applications speaks with each IoT gadgets utilizing sensible connectors. APIs show information that empowers those gadgets to send information to the application, going about as an information interface.

HAND HELD DEVICE:

The observing of the information should be possible in online or portable application. These applications are operated in portable device like mobile phones which has LCD to display the data.

5 BlynkIoT Platform:

Blynk is a Platform with IOS and Android applications to control Arduino, Raspberry Pi and the inclinations over the Internet. Regardless of whether the Arduino or Raspberry Pi is connected to the Internet over Wi-Fi, Ethernet or this new ESP8266 chip, Blynk will prepare you on the web and for the Internet of Your Things. Blynk was intended for the Internet of Things. It can handle equipment distantly, it can show sensor information, it can store information, imagine it and do numerous other cool things.

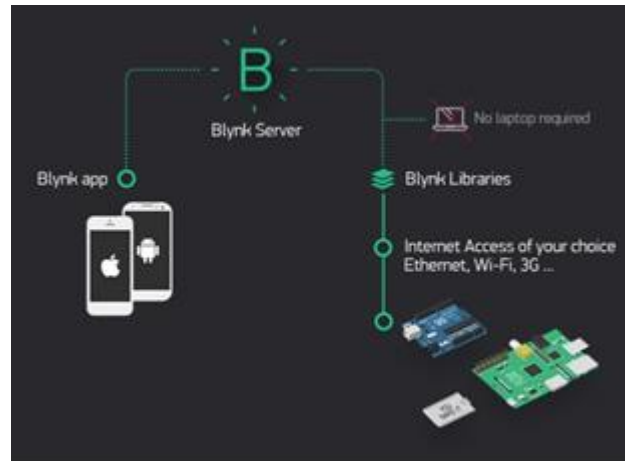
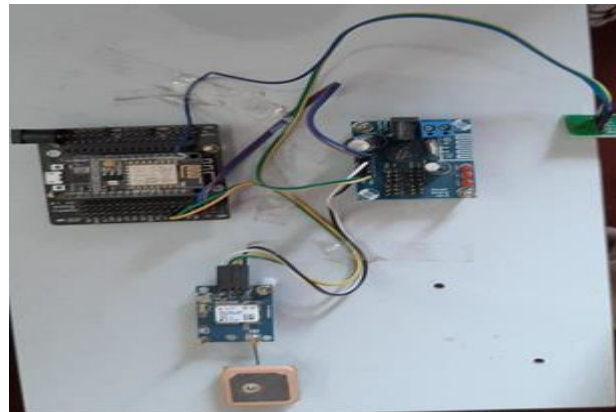

Fig-3

6. Result



7. Conclusion

All in all, this application is intended for locating missing ladies. The arrangement addressed in this paper takes the upsides of PDAs which offer rich features like Google maps, GPS, SMS and so on. A portion of the best works executed in past depends on SMS based tracking which isn't useful to get a precise area in our proposed framework. We have given continuous following. We have added Geo-fencing and Emergency messaging services to improve the framework. Following and administration (audience) for listening messages coming from ladies' side. On the ladies' side audience administration consistently runs in foundation, at parent side used to send SMS for area of ladies. Parent side audience used to listen Women answer for area demand. There are two principle capacities at ladies side. To tune in and gets area from satellites or organization supplier. Audience is a vital help at Women side to listen all SMS approaching and answer SMS which simply identified with area demands. At the point when parent sends area solicitations to the Women side, at ladies side it listens message and code for this message to answer the area demands on map at parent side. The application is modified to listen the predefined strings. At long last for this application has space for the upgrade. Crisis cautions such highlights can be added to improve framework. The proposed framework will be improved in the later work.

References:

1. E.Anupriya, A.Alsameema, M.R.Elakhia, B.Jayameera, "Smart Safety System", International Journal of Science and Technology, March-2020.
2. N.T.Sowmya, D.Triveni, D.Keerthana, A.Vasanthalakshmi, K Padma Priya, G.Kavya, "Women Safety System Using IOT", International Journal of Science and Technology, March-2020.
3. B.Sathyasri, U.JaishreeVidhya, G.V.K.JothiSree, T.Pratheeba, K.Ragapriya, "Design and Implementation Of Women Safety System Based On Iot Technology", International Journal Of Recent Technology and Engineering, April-2019.

4. C.Priya,Ramya, C.Bety, D.Harini, G.shilpa, D.sivakrithiga, “One Touch Alarm for Women Safety Using Arduino”,International Journal of Science and Technology, April-2019.
5. AbhijitParadkar, Deepak Sharma, “All In One Intelligent Safety Systemfor Women Security”,International journal of computer application, November -2015.
6. WasimAkram, Mohit Jain, C. SweetlinHemalatha, “Design of a Smart Security Device using Iot”, International conference on Recent Trends in advanced computing-2019.
7. Dinah punnoose, S.Vasankari, K.Venkatesh, E.Ashokd, R.Prashanth, “Women Safety Measurement Tracking System Using Raspberry pi”, International journal of computer application, August -2020.
8. D.G.Monisha, M.Monisha, PavithraGunasekaran, “Women Safety Device and Application-FEMME”,Indian Journal of Science and Technology, March -2016.
9. Dr.Sridharmandapati, SravyaPamidi, SriharithaAmbati, “A Mobile BasedSafetyApp(I Safe App)”, IOSR Journal of Computer Engineering (IOSR-JCE) -2015.
10. Nitishree, “IOT Based Smart GPS Device for Women and Women Safety Applications”,International Journal of Engineering Research and General Science Volume 4, May-June, 2016.
11. N. Nivetha, B. Anna Poorani, T. Gayathri, B. Monica Nancy and H. K. Monisha, ” Data and User Confidentiality Privacy Preservation in Distributed Servers “,Bioscience Biotechnology Research Communications, Special Issue Volume 13. Number (4), 2020.
12. RahmathNisha S, S. Kiruthika,A. Ajay Krishna, A. Mohamed Ayub and A. K. Harieswar, “Intelligent Smart Home Security and Automation System using IotBlynk Server “ ,Bioscience Biotechnology Research Communication 13 (4), 184-191,2020.
13. Pavithra, M., Sindhana, A.M., Subajanaki, T. and Mahalakshmi, S., 2021. “Effective Heart Disease Prediction Systems Using Data Mining Techniques”. Annals of the Romanian Society for Cell Biology, pp.6566-6571.
14. V.Kalpna,C.Shyamala, “TEELR: Trust enhanced Energy Efficient Load balanced Routing for Ad hoc Networks” , Test Engineering and Management ISSN: 0193-4120 Page No. 6029 – 6034,2020.