

## Wireless Green House Monitoring System Using Raspberry PI

Tripura Pidikiti<sup>a</sup>, Kishore Yadlapati<sup>b</sup>, Fredric Samson Kirubakaran Sakthiraj<sup>c</sup>, Madhavi Gudavalli<sup>d</sup>, K. Reddy Madhavi<sup>e</sup>

<sup>a</sup> Assistant Professor, Department of EEE, RVR & JC College of Engineering, Guntur, India.

<sup>b</sup> Assistant Professor, Department of EEE, JNTUK University College of Engineering Narasaraopet, Guntur, India.

<sup>c</sup> principle Architect, Bank of New York Mellon, New York

<sup>d</sup> Assistant Professor, Department of CSE, JNTUK University College of Engineering Narasaraopet, Guntur, India.

<sup>e</sup> Associate Professor, Department of CSE, Sree Vidyanikethan Engineering College, Tirupati, India.

**Article History:** Received: 11 January 2021; Accepted: 27 February 2021; Published online: 5 April 2021

**Abstract:** A Greenhouse is a framed structure that is used for the production of fruits, vegetables, flowers, and any other plants that require special conditions of temperature and humidity. Greenhouses warm up during the day-times when sun-rays penetrate through them, which heat the plant, soil and the structure. The greenhouse effect is a natural phenomenon and is very beneficial to the human being. With lack of proper green house monitoring and control system the production decline which leads to loss. There are many challenges starting from plant growth to maintenance for which monitoring and control of greenhouse is needed. This paper explains the design and implementation of a network with wireless sensors for greenhouse environment monitoring and controlling. This greenhouse control system is controlled by Raspberry pi with its wifi capability that is attached to a temperature sensor, soil moisture sensor, Light Dependent Resistor (LDR) sensor, 12V DC fan and pump. With the monitoring and control of greenhouse the performance of the system and production can be increased. A prototype was designed and built up whose results were presented.

**Keywords:** Greenhouse, Wireless Sensor Network, ThingSpeak, Twilio cloud.

### 1. Introduction

The Internet of things (IoT) is an organization of physical objects and things that are installed with sensors, programming, and different innovations to associate information with different gadgets and frameworks over the Internet. The idea of the IOT is being advanced because of the association of several AI mechanisms, product sensors, installed frameworks, conventional fields, remote sensor organizations, control frameworks, computerization and mechanisms, product sensors, installed frameworks, and many other procedures in permitting the Internet of things [1]. In the quickly developing world, IoT innovation is the most interchangeable innovation with objects relating to the idea of the "smart home", many other procedures in enabling the Internet of things, includes gadgets and machines that helps in normal environments and can be controlled using appliances associated with the ecosystem, such as cell phones and brilliant speakers. IoT is likewise applied in medical services frameworks [2]. There are various genuine worries about perils in the development of IoT, particularly in the territories of protection and security [3], thus industry and government move to address these worries which has started including the improvement of international standards [4], [5].

In recent days, due to inevitable climatic and weather changes farmers were most affected, due to its effect on the crop production. Due to this, a need for alternative way to fight against the affects of climatic change arised and it resulted in greenhouse technology. Greenhouse technology is the way to cultivate horticultural family in a deliberate and well designed artificial form. Forming with greenhouse system consists of components which can control the climate inside the greenhouse. The control components depends on the design requirement, it would be different for different plant growth [6]. Certain guidelines were provided by the international committee on how to build the structure of green house and its orientation for optimized construction. In this paper [7] it was also explained where to measure the parameters necessary for maintaining the greenhouse environment. It was mentioned that, parameters like radiation, temprature, gasses, water and nutrients are needed to be collected as they affect the plant progress. The corresponding sensing values of these parameters is needed to assign to sensors to measure the value of environmental condition in greenhouse. Researches on IoT based smart greenhouse has been popular recently. The IoT 'ThingSpeak' web service acts as a host for the variety of sensors to monitor the sensed data using a channel ID and read API key is presented in [8]. In this paper, an automated greenhouse farming system is designed by using Raspberry Pi, thinkspeak cloud, relays and sensors as main components. In our system, the temperature, moisture and light sensors are used for collecting the data from the greenhouse environment. Overview of the proposed system layout can be seen in Figure 1.

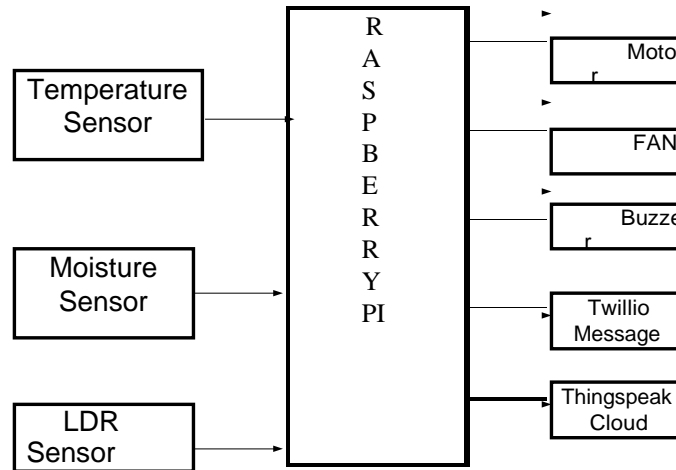
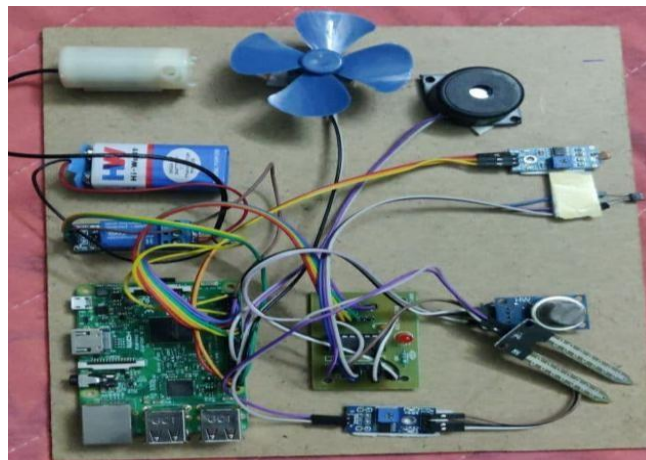

**Figure 1** Proposed system layout

### Sensor Integration

Four sensors namely temperature, moisture and light sensors were used to collect data for monitoring the green house system. The humidity and temperature sensor DHT11 was connected to R Pi. DHT11 sensor output Pin is connected to GPIO17 of raspberry pi. The probes of the soil moisture sensor were made up of stainless steel was used to measure the water content in the soil. The sensor converts the measured moisture content into equivalent electrical signal (voltage) in analog form. When the soil consists of more water, higher voltage was given as output. As analog inputs are not compatible to R pi an analog to digital converter (ADC) ADS1115 is used to connect the moisture sensor to GPIO of R Pi.

LDR sensor is used to sense the intensity of light. It is connected to the GPIO pin of R Pi via few volts source and a one micro farad capacitor. The prototype model of the entire system is shown in figure 2.



**Figure 2** Prototype model of the system

### 1. Wireless Sensor Network Development

The environmental wireless sensor node association was the subsequent stage in improvement of the greenhouse monitoring structure. The Wi-Fi technology was used for wireless communication, Wi-Fi technology was used, particularly the 802.11n Wi-Fi which will be operated at 2.4 GHz with 600 Mbps data rate. The R Pi was used to gather and process the data of greenhouse environment. The R Pi was used to set up association amongst the sensor nodes, together with the mobile phone which serve as the data aggregator.

### 2. Working of Prototype

The working of prototype model is explained with the help of a flowchat shown is figure 3.

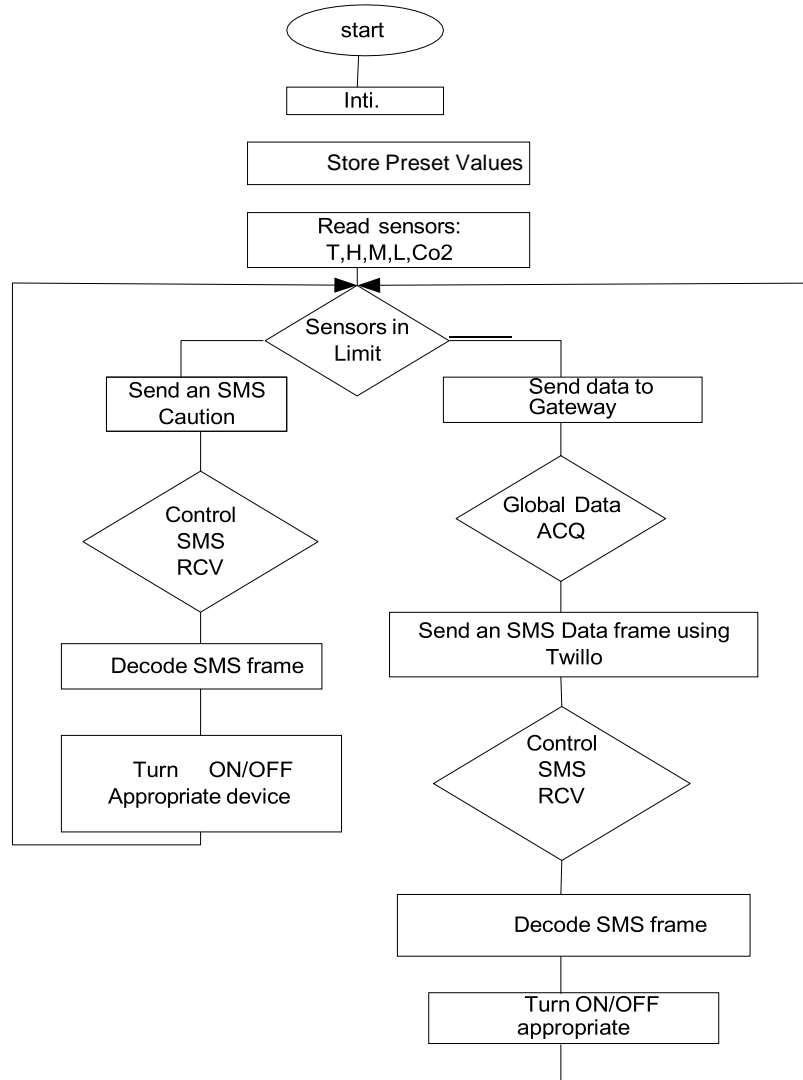

**Figure 3** Flow Chart of the system

The temperature is verified by the temperature sensor and if it goes over a preset limits the system operates the cooler such that the temperature comes back to the set values. A splash gadget is used to control the moisture within the set limits. The DHT11 sensor is used which contains humidity and temperature sensors. DHT11 can be easily interfaced with micro- controller [19-22].

SEN92355P sensor from Grove innovation is used to verify the dampness [9-10] and if earth is dry, the framework turns on a siphon. A gas indicator sensor FC-22-1 is utilized to identify CO2 rate [11-13]. At the instant when the level of CO2 is high, the ventilator is turned on by the system to remove the air. A light control mechanism is also combined if there arises a need of longer helping hours not nevertheless the typical helping hours [15]. All the preset boundaries for temperature, stickiness, dampness are client characterized and rely upon the plant developed and atmosphere prerequisites.

The real time data from the sensors is read by using sensor node and compared with the reference values set as limits. The environmental conditions needed for a particular plant type will be taken into account to set the limit values [14-15]. In this system the limits considered were as given below.

T: 28C, H: 40%, M: 65%, CO2: 13%, L: ON

If the values read from the sensors were within the limits, the data will be sent to the gateway and the node checks the arrival of new SMS for the required GLOBAL data If received, SMS data frame was sent by the to the master mobile phone with the sensor values. The SMS looks like:

T: value(C), H: value (%), M: value (%), CO2: value (%), L: status (ON/OFF).

The hub likewise checks if any control sms is received., If the control SMS was received, and as a response to it the system responds to the frame content while the SMS is decoded and the devices were turned ON/OFF based on the frame contents[17]. The frame control data is assigned with letters for each device and the status which looks like:

S: status, C: status, L: status, P: status,V: status

Where S for the spray, C for the cooler, L for light, P for pump and V for ventilator. This data can be sent either from the gateway GUI on demand or from the master mobile phone directly. If the sensors sense a data out of limits, an SMS is sent to the master mobile as a caution to take decision based on the information provided (e.g., if T exceeds, turn on COOLER). If the caution message is answered then the system will obey the command otherwise, the system itself will take the decision automatically. The sensors data is received by the system and sent to the Thing speak.

### 3.Results and Discussion

The framework comprises of a temperature sensor, stickiness sensor, dampness sensor, light control and CO2 sensor. The temperature sensor screens the temperature and in the event that it goes over a preset worth, the framework turns on a cooler until the temperature get steady. The stickiness is additionally observed and a splash gadget is actuated if moistness goes above cutoff points. The sensor used to screen temperature and stickiness is DHT11 sensor which is a 1wire interface temperature and dampness sensor complex with an adjusted computerized signal yield [14].In the gateway side, the system receives data from sensors to send it to ThingSpeak. The sensors data will be displayed and control switches are available for various devices. The DCS (Devices Control Switch) is used to send control data frame to the sensor node.

Temperature graph: This graph (figure 4) shows the recording of temperature management from day1-day 7 using Thingspeak which is controlled by the LM-35 sensor automatically.



**Figure 4** Temperature Management recording using thingspeak

#### 2.1 LDR graph

This graph (figure 5) indicates the recording of the control of Light Energy from day1-day 7 using Thingspeak which is controlled by the LDR sensor automatically.



**Figure 5** Light-Energy Control recording using thingspeak

#### 2.2 Moisture graph

This graph (figure 6) indicates the recording of the control of Soil Moisture from day1-day 7 using Thingspeak which is controlled by the Soil Moisture sensor automatically.



**Figure 6** Soil moisture control recording using thingspeak

*2.3 Gas Graph*

This graph (figure 7) indicates the recording of the control of harmful gases from day1-day 7 using Thingspeak which is controlled by the Gas sensor automatically.



**Figure 7** Gas control recording using thing speak

*2.4 Information bundle*

The data sent from the sensor hub to the entryway through the WSN modem come in type of a SMS bundle through the Twilio Cloud as shown in figure 8. The bundle contains boundary data of various sensors, which is extricated forward by the passage programming and showed in the GUI board. A similar cycle is utilized to control the various gadgets in the sensor hub.



**Figure 8** SMS data frames using Twilio cloud

The Wi-Fi sends information between sensor hub and door and the other way around in grouping to screen and control the framework. Figure 8 shows the SMS outline which contains the data from the sensor hub to the entryway. Every boundary read from the sensor hub spoke to utilizing a relative letter, for instance: T for temperature, H: for dampness, etc. The estimation of the boundary is trailed the letter appropriately and every boundary isolated from the other utilizing a semicolon. While getting the edge in the passage programming, every boundary read in explicit bytes and showed in the GUI.

## 5. Conclusions

The inspiration for this paper is to use the Wireless Sensor Network in nursery checking and control. The framework is to peruse various boundaries in nursery like temperature, dampness, light, and harmful gases. The framework center is Arduino viable innovation and the WSN dependent on Wi-Fi is utilized for short distance correspondence and WSN for world wide framework correspondence. A GUI board is planned utilizing Thing Speak programming to screen and control the sensor hub parts and gadgets. All the boundaries in the framework could be adjusted by the plant type and atmosphere pre requisites. The framework is tried in the lab, and a field test could be performed for field confirmation in future.

## References

1. Dan LI, Xin C, Chongwei H, Liangliang J. Intelligent agriculture greenhouse environment monitoring system based on IOT technology. In 2015 International Conference on Intelligent Transportation, Big Data and Smart City 2015 Dec 19 (pp. 487-490). IEEE.
2. Xu B, Da Xu L, Cai H, Xie C, Hu J, Bu F. Ubiquitous data accessing method in IoT-based information system for emergency medical services. IEEE Transactions on Industrial Informatics. 2014 Feb 17;10(2):1578-86.
3. Xu B, Da Xu L, Cai H, Xie C, Hu J, Bu F. Ubiquitous data accessing method in IoT-based information system for emergency medical services. IEEE Transactions on Industrial Informatics. 2014 Feb 17;10(2):1578-86.
4. Singh VP, Dwarakanath VT, Haribabu P, Babu NS. IoT standardization efforts—An analysis. In 2017 International Conference On Smart Technologies For Smart Nation (SmartTechCon) 2017 Aug 17 (pp. 1083-1088). IEEE.
5. D. Miorandi et al., "Internet of things: Vision, applications and research challenges," Ad Hoc Networks 10 (2012) 1497–1516.
6. Benjamin, L., Both, AJ., Franklin, J., Holroyd, G., Incoll, LD. (2015). "Guidelines for measuring and reporting environmental parameters for experiments in greenhouses". Plant Methods 11, 43.
7. Kasaei S. H., Kasaei S. M., Kasaei S. A., "Design and Development a Control and Monitoring System for Greenhouse Condition Based-On Multi Agent System"
8. S. Pasha, "ThingSpeak Based Sensing and Monitoring System for IoT with Matlab Analysis", International Journal of New Technology and Research (IJNTR) ISSN: 2454- 4116, Volume-2, Issue-6, June 2016, pp. 19-23
9. <http://www.robotshop.com/media/files/pdf/grove-moisture-sensor-sen92355p.pdf>, [Díaz JM, Acuña SR, Romero WC, Díaz BB, Huerta GV, Luna JM, Martínez PZ, Lara OG. CALIBRACIÓN Y CARACTERIZACIÓN DE UN SENSOR DE CAPACITANCIA DE BAJO COSTO PARA ESTIMAR LA HUMEDAD DEL SUELO.
10. Ruiz-Larrea A, Roldán JJ, Garzón M, del Cerro J, Barrientos A. A UGV approach to measure the ground properties of greenhouses. In Robot 2015: Second Iberian Robotics Conference 2016 (pp. 3-13). Springer, Cham.
11. Angin DP, Siagian H, Suryanto ED, Sashanti R. Design and Development of the Trash Splitter with Three Different Sensors. In Journal of Physics: Conference Series 2018 Apr 1 (Vol. 1007, No. 1, p. 012057). IOP Publishing.
12. Mekki M, Abdallah O, Amin MB, Eltayeb M, Abdalfatah T, Babiker A. Greenhouse monitoring and control system based on wireless Sensor Network. In 2015 international conference on computing, control, networking, electronics and embedded systems engineering (ICCNEEE) 2015 Sep 7 (pp. 384-387). IEEE.
13. Benjamin, L., Both, AJ., Franklin, J., Holroyd, G., Incoll, LD. (2015). "Guidelines for
14. measuring and reporting environmental parameters for experiments in greenhouses". Plant Methods 11, 43
15. Andrey Somov, Alexander Baranov, Denis Spirjakin, Andrey Spirjakin, Vladimir Sleptsov, Roberto Passerone, "Deployment and evaluation of a wireless sensor network for methane leak detection", 2012.
16. Data Acquisition of Greenhouse Using Arduino-Journal of Babylon University/Pure and Applied Sciences/ No. (7)/ Vol. (22): 2014.
17. Zhou Y, Zhou Q, Kong Q, Cai W. Wireless temperature & humidity monitor and control system. In 2012 2nd International Conference on Consumer Electronics, Communications and Networks (CECNet) 2012 Apr 21 (pp. 2246-2250). IEEE
18. Working of relay board <https://www.freetronics.com.au/pages/relay4-4-channel-relay-driver-module-quickstart-guide#.WpuAwuhubIV>
19. Working of light dependent resistor. <http://www.edgefxkits.com/blog/light-dependent-resistor-ldr-with-applications/>
20. Working of DHT11- Humidity sensor. <https://howtomechatronics.com/tutorials/arduino/dht11-dht22-sensors-temperature-and-humidity-tutorial-using-arduino/>

21. Datasheet of dht11 humidity sensor.
22. <https://cdn-learn.adafruit.com/downloads/pdf/dht.pdf>
23. Datasheet of DS18B20-temperature sensor. <https://datasheets.maximintegrated.com/en/ds/DS18B20.pdf>
24. Working of soil moisture sensor.
25. <https://randomnerdtutorials.com/guide-for-soil-moisture-sensor-y1-69-or-h1-69-with-the-arduino/>
26. Raspberry-Pi.<https://www.raspberrypi.org/>