

Application of IOT for Human Safety on Road

Tripura Pidikiti^a, Kishore Yadlapati^b, Gudavalli Madhavi^c, and K. Reddy Madhavi^d

^aRVR & JC College of Engineering, Guntur, India

^bJNTUK University College of Engineering Narasarpot, India

^cJNTUK University College of Engineering Narasarpot, India

^dSree Vidyanikethan Engineering College, A.Rangampet, Tirupati

Article History: Received: 11 January 2021; Accepted: 27 February 2021; Published online: 5 April 2021

Abstract: Two wheelers (motor bikes) are most used easy and economic means of transportation and it also has become unsafe because of the tremendous increase of road accidents. When two-wheeler met with an accident, it is difficult to spot the neighborhood of the accident and mammoth loss occurs due to time factor. This paper presents Internet of Things based accident detection and prevention system. This is a novel system divided into four parts: first to identify the accident to send signal to emergency center along with location using Arduino based Global Positioning System and Global System for Mobile Communication and remaining are to warn to prevent the accidents like an accelerometer to determine the velocity and tilt of the vehicle, Infrared sensor to detect any obstacles and an alcohol sensor.

Keywords: IOT, IR Sensor, Arduino, GPS, GSM

1. Introduction

Safety over transportation is increasing interest because of many deaths across the globe. Traffic hazards are one of the key issues to be addressed with when it comes to transportation [1]. The increased usage of vehicles has led to increased chaos on the roads. This increased chaos has led to increased number of accidents. According to the Global status report of WHO having information from about 180 countries, shows that worldwide the total number of deaths occurring in road accidents has attained to 1.25 million per year, with the maximum road traffic death rates in low-income countries [2]. According to a news report, eighty percentages of road accidents are caused by human error. Some of the victims are Elder people, Children, pedestrians crossing the roads [3]. Some of the causes for road accidents were mentioned in are due to bad conditions of the roads, drunk driving, potholes, unskilled drivers etc.

Accidents involving ineligible drivers are huge in number. These incompetent people, to a larger extent, comprised of teenagers with age between 15-18yrs. Teens go through their adolescence period where they are pumped up with emotions hence this leads to rash and reckless driving. They try to show off by doing stunts on the bike which leads to disastrous results. Numerous rules and policies were implemented by the government to avoid road accidents. Hence there must be a unique solution for transportation that could drastically reduce road accidents [4].

This paper mainly focuses on preventing and detecting the accidents using microcontroller-based system with 3 axis accelerometer sensors to detect the over speeding and slope of the vehicle and IR sensor to sense the motor vehicle that is coming on its way [5].

A system with GPS and GSM oriented is introduced. This system will constantly determine latitude and longitude along with the speed of the affecting vehicles with respect to time. The accelerometer will allow us to identify the velocity of the vehicle and when this value crosses the defined value for that particular geographical coordinates calculated from real time Google Map, an indication will be sent as SMS with the help of Arduino and GSM module [6]. This may increase the probability of reducing accidents.

2. Methodology

The Internet of Things (IoT) is the interconnection of uniquely identifiable embedded computing devices within the existing Internet infrastructure, which will help us in integrating various components of the system coherently [7]. This method has several advantages like high performance, user friendly even an incompetent can use it.

This paper mainly concerned with two aspects i.e. prevention of accident to the feasible extent and the detection of accident occurred and inform it to the people concerned to offer the essential medical aid for the victim and save him/her from death.

2.1 Prevention Method

Considering the facts from the surveys that the maximum accidents occur due to the driver's incapability of vision during the night and foggy atmosphere and also the driver's incapability is due to the consumption of alcohol we are using IR sensor and the MQ3 sensor on a microcontroller for this purpose.

IR sensor is used to help the driver in the foggy atmosphere by giving a signal to the driver that he is approaching an obstacle or another vehicle in front of him. This warns the driver at a considerable distance so that he can react to the situation[8].MQ3 sensor is used to detect the alcohol content of the driver and a warning is given based on the percentage of alcohol consumed. If the percentage is high the microcontroller connected to the key will not let the engine start [9].The circuit diagram for the prevention system is shown in Fig.1. The major components of the circuit are IR sensor, MQ3 sensor, relay, DC motor and LCD display connected to Arduino UNO.

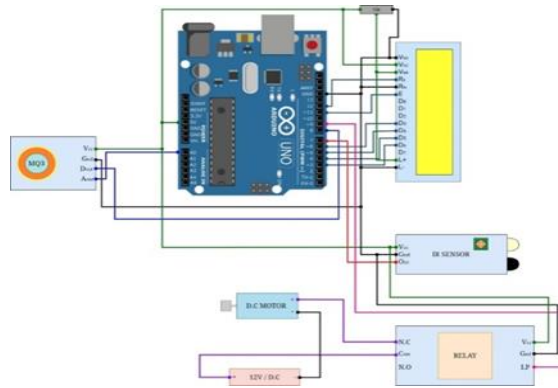

Fig.1. Circuit diagram of the detection system

2.2. Detection Method

In case of an accident occurred at a place it is necessary to provide the victims with immediate medical assistance to save them from death. So, detection of the accident can help in fulfilling this purpose. In this paper an accelerometer, GPS module and GSM module interfaced on a micro controller to detect the accident is used.

The accelerometer is a triple axes sensor to detect that the accident is occurred. GPS sensor is used to locate the GPS coordinates where the accident is occurred [10]. Now the information is sent as a text message to the authorities or the people concerned by GSM module asking medical assistance to that place. The circuit diagram for the detection system is shown in Fig.2. The major components of the circuit are accelerometer (ADXL335), GPS module (SIM 98ML), GSM module (SIM 900A) and LCD connected to Arduino UNO.

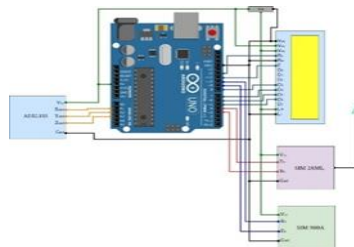

Fig.2. Circuit diagram of the detection system

3. Component Description

The different components used in the prototype model are explained in this section.

3.1.Arduino Mega

The Arduino Mega is a microcontroller board based on the Atmega2560. It has 54 digital input/output pins (of which 14 can be used as PWM outputs), 16 analog inputs, 4 UARTs (hardware serial ports), a 16 MHz crystal oscillator, a USB connection, power jack, an ICSP header, and a reset button. The pin diagram of Atmega 2560 is shown in Fig.3.



Fig.3. Pin diagram of Arduino Uno

3.2. Arduino Uno

Arduino Uno is a microcontroller board based on 8-bit ATmega328P microcontroller. Along with ATmega328P, it consists other components such as crystal oscillator, serial communication, voltage regulator, etc. to support the microcontroller. Arduino Uno has 14 digital input/output pins (out of which 6 can be used as PWM outputs), 6 analog input pins, a USB connection, A Power barrel jack, an ICSP header and a reset button.The Arduino uno and its pin diagram are shown below in Fig.4.



Fig. 4. Pin diagram of Arduino Mega

3.3. GPS module (SIM28ML)

This GPS receiver modem is based on SIMCOM's SIM28M/SIM28ML GPS module. SIM28ML is a standalone or A- GPS receiver. With built in LNA, SIM28ML can relax antenna requirements and don't need an external LNA. SIM28ML can track as low as -165dBm signal even with no network assistance. SIM28ML has outstanding little power consumption characteristics (acquisition 17mA, tracking 16mA). SIM28M supports various location and navigation applications Autonomous GPS, QZSS, SBAS ranging (WASS, EGNOS, GAGAN, MSAS), DGPS, A-GPS. The antenna circuitry built in this modem is capable of receiving signals even at difficult locations where other modems fail to receive signal. Use an external antenna of 155.42MHz. The GPS module and pin diagram are shown in Fig.5.

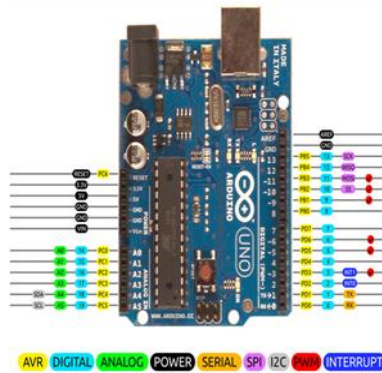

Fig.6. Alcohol sensor pin diagram

3.5. Accelerometer (ADXL 335)

ADXL 335 module is a small, low power triple axis MEMS accelerometer from Analog Devices with extremely low noise. The sensor has a full sensing range of ± 3 g. It can measure the static acceleration due to gravity in tilt-sensing applications, as well as dynamic acceleration resulting from motion, shock, or vibration. The sensor works on power between 1.8V to 3.6VDC (3.3V optimal), and typically consumes just 350 μ A of current. However, an on-board 3.3V regulator makes it a perfect choice for interfacing with 5V microcontrollers such as the Arduino. The pin diagram is shown in Fig.7.

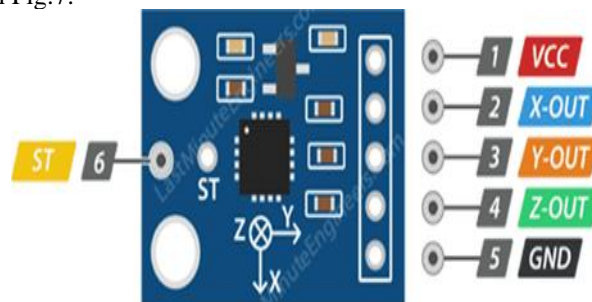

Fig.7. Accelerometer pin diagram

4. Implementation

The module which we have developed is operated by two Arduino boards namely UNO and MEGA both are powered by ATMEL microprocessors. The code is dumped into these processors using Arduino IDE software which is an open source software for developing projects based on IOT applications. The code is developed using

functions with each function for the operation of sensors and modules. The block diagram for the working of the accident detection part of the module is shown in Fig.8.

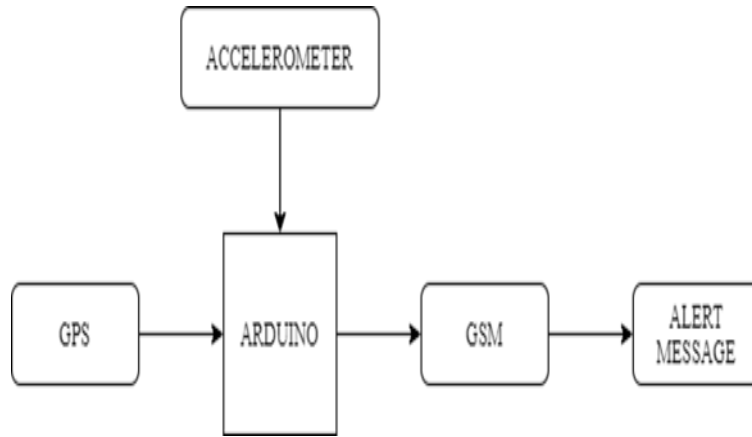

Fig.8. Accident detection system block diagram

Initially when the module is powered the all the components begin to calibrate themselves. The GPS module searches for coordinates, GSM activates the sim functions, and the ACCELEROMETER senses the three-dimensional accelerations and adjusts itself. When the initialization is complete the accelerometer sends its readings to the Arduino which compares it repeatedly with the defined limits to determine that the vehicle is safe. In case of any abnormal variations in the vehicle position, the processor detects this abnormality and sends an alert message to the authorities in the form of text message through the GSM module. The block diagram for the working of the accident prevention part of the module is shown in Fig.9.

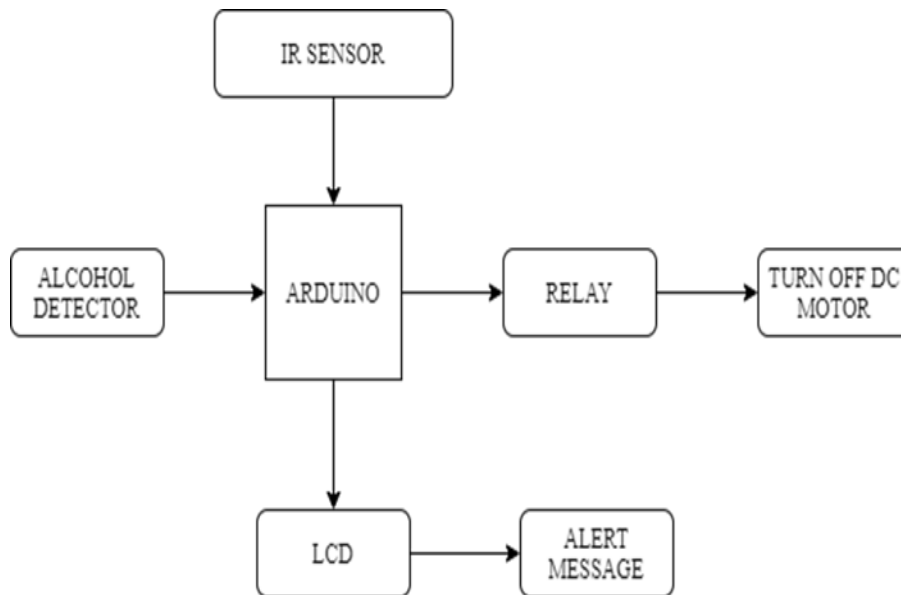

Fig.9. Accident prevention system block diagram

In this part the other Arduino board is interfaced with the MQ3 sensor to detect alcohol and an IR sensor to detect the obstacles. When this module is powered on the MQ3 and IR sensors calibrate themselves to detect the presence of alcohol and obstacles. In case of detection of alcohol in the vehicle the Arduino trips off the vehicle starting circuit using the relay connected to it. In case of an obstacle approaching the driver is alerted through led flashing and an alert communication displayed on the LCD screen. The developed code is written in the “ARDUINO IDE” software which is available at Arduino official website for various operating systems. In this work two codes are developed each for accident detection and alcohol detection systems and both the codes are uploaded into their respective Arduino boards. The flow charts for both are shown in figure 10 and figure 11.

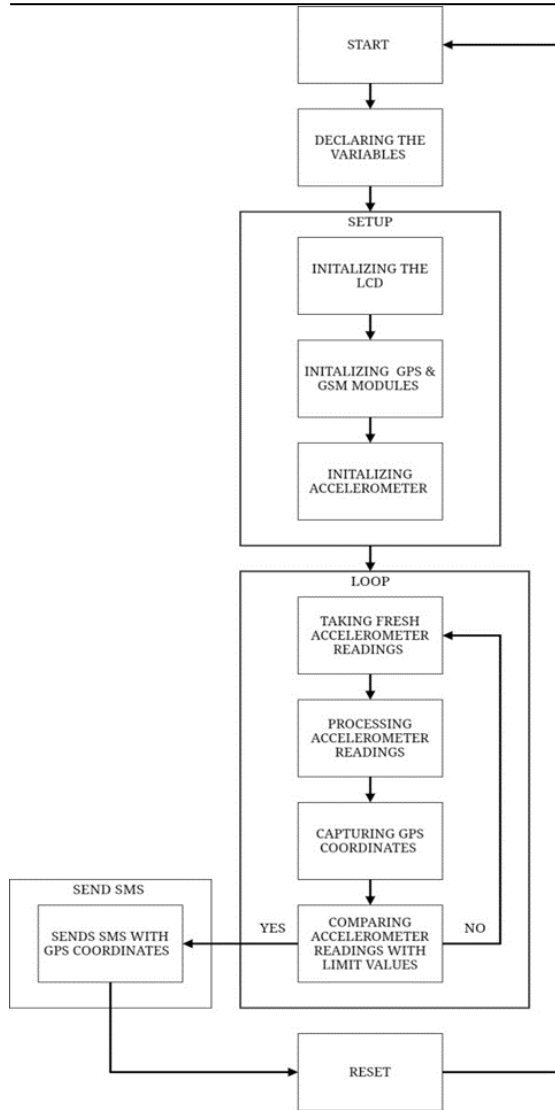

Fig.10. Accident detection system flow chart

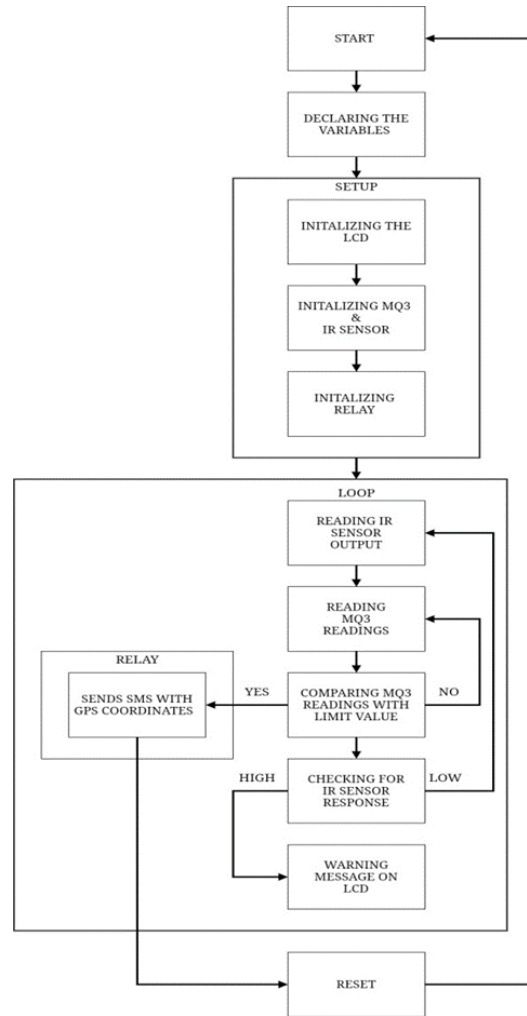

Fig.11. Accident prevention system flow chart

5. Working of Prototypye

The developed prototype is a closed loop system as shown in Fig.12 and does not require manual interference to operate except in one case, where there may be a chance of false alarm getting triggered. Both the accident detection and alcohol sensing are closed loop systems where the Arduino collects the inputs from the analog sensors and compares it with the defined limits. Unless there is a violation of limits the system does not operate.

The accelerometer readings are constantly compared with the fixed limits and the GPS coordinates are constantly recorded by the Arduino processor. In case of violation of these limits the program loop is broken down and a text message with the latest recorded live coordinates is generated and sent to the person who is close to the driver or to the concerned authorities.

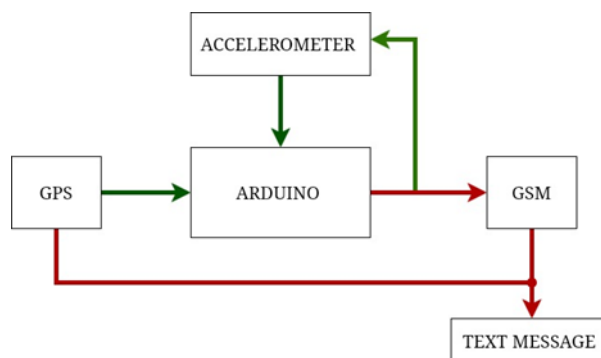

Fig.12. Working sequence of accident detection system

Similarly, in alcohol detection, the alcohol concentration values are constantly recorded and compared with the minimum limit and the status of the IR sensor is also checked for HIGH or LOW. When the atmospheric alcohol concentration is greater than the defined limit the ARDUINO processor trips the relay circuit preventing the vehicle from turning on. In case of IR sensor, when the status is high an alert message is displayed on the LCD screen. The working sequence of accident prevention system is shown in Fig.13.

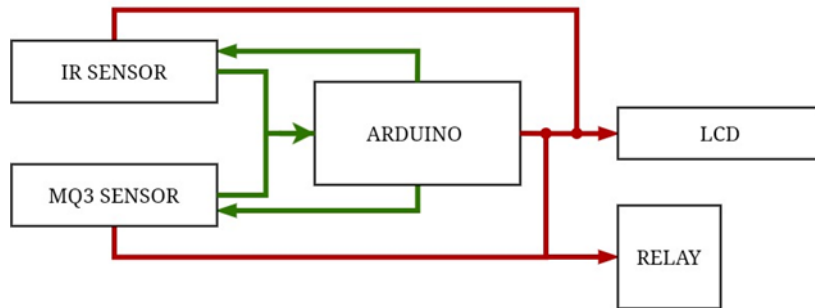
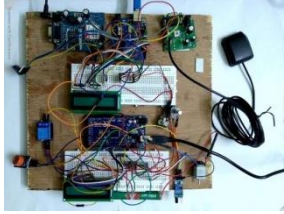
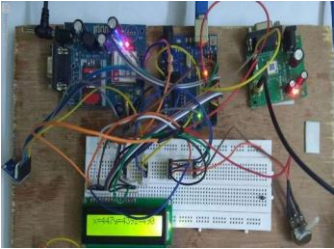
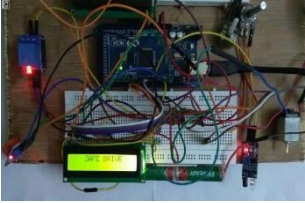
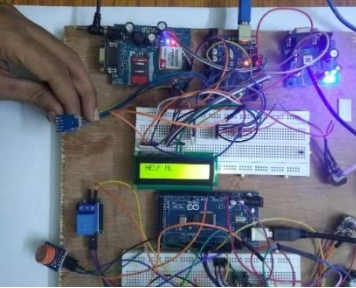
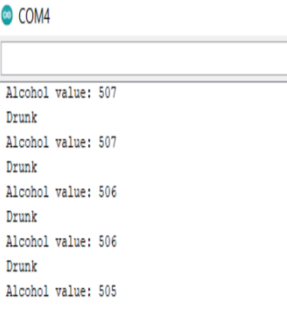
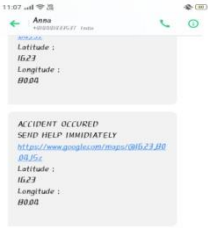

Fig.13. Working sequence of accident prevention system

The conditions which occur mostly in a practical accident are considered as test cases and the conditions to satisfy the requirements of an accident and the tests are according to these conditions and the results were captured. These test conditions are called as test cases in which the prototype operates. The results are shown in the Table 1

Table 1: Working of prototype under different stages		
Idle State		When the system is in off state
Initializing state		When the system is on and the accelerometer is calibrating itself.
Safe drive state		When the system is ready, and the vehicle is safe to proceed.
Danger state		When there is an abnormal change in the position of accelerometer alert message will be displayed in the LCD.

<p>Intoxicated state</p>	 <pre> COM4 Alcohol value: 507 Drunk Alcohol value: 507 Drunk Alcohol value: 506 Drunk Alcohol value: 506 Drunk Alcohol value: 505 </pre>	<p>When the driver is drunk beyond the safe limit the MQ3 detects the alcohol and alerts the processor which switches the relay and disconnects the car starting system.</p>
<p>Alert SMS</p>	 <pre> 11:07 AM Anna ACIDENT OCCURED SEND HELP IMMEDIATELY https://www.google.com/maps/@16.23,80.85, Latitude : 16.23 Longitude : 80.85 </pre>	<p>This is the message which will be sent to the authorities.</p>

6. Conclusions

In this paper a low cost, lightweight prototype is developed which can be included into any vehicle. It is not only cost effective but also light and dependable. This model can prevent the loss of lives due to late identification of accidents as this model instantly sends the site of the accident to the authorities intern medical help is send to accident location immediately to prevent loss of lives. The developed prototype also prevents an accident from occurring by alerting the driver in case of an obstacle approaching the vehicle. Further it prevents the car from starting if the driver is drunk and forcing him to take a taxi or other means of transport than hazardous self-driving.

References

1. D. Selvathi, P. Pavithra and T. Preethi, "Intelligent transportation system for accident prevention and detection, " in 2017 International Conference on Intelligent Computing and Control Systems (ICICCS), India, 2017.
2. Global status report on road safety 2018.
3. V. Ahmed and N. P. Jawarkar, "Design of Low Cost Versatile Microcontroller Based System Using Cell Phone for Accident Detection and Prevention, " in 2013 6th International Conference on Emerging Trends in Engineering and Technology, India, 2013.
4. T. Noguchi and N. Tanaka, "Efficient vehicle visualization system for safe driving in VANETs, " in 2017 IEEE SmartWorld, Ubiquitous Intelligence & Computing, Advanced & Trusted Computed, Scalable Computing & Communications, Cloud & Big Data Computing, Internet of People and Smart City Innovation (SmartWorld/SCALCOM/UIC/ATC/CBDCOM/IOP/SCI), usa, 2017.
5. Chunmei Ma, Xili Dai, Jinqi Zhu, Nianbo Liu, Huazhi Sun, Ming Liu, "DrivingSense: Dangerous Driving Behavior Identification Based on Smartphone Autocalibration", Mobile Information Systems, vol. 2017, Article ID 9075653, 15 pages, 2017.
6. P. Chen and S. Liu, "Intelligent Vehicle Monitoring System Based on GPS, GSM and GIS," 2010 WASE International Conference on Information Engineering, Beidai, China, 2010, pp. 38-40, doi: 10.1109/ICIE.2010.17.
7. Birje, M.N., Hanji, S.S. Internet of things based distributed healthcare systems: a review. J. of Data, Inf. and Manag. 2, 149–165 (2020). <https://doi.org/10.1007/s42488-020-00027-x>.
8. Xiaoyan Yu and Marin Marinov, "A Study on Recent Developments and Issues with Obstacle Detection Systems for Automated Vehicles: review", Sustainability 2020, 12, 3281.
9. Prof. Dr. D.G.Jha and Swapnil Buva, "Alcohol Detection in Real-Time To Prevent Drunken Driving", IOSR Journal of Computer Engineering (2018) , pp. 66-71.
10. P. Parmar and A. M. Sapkal, "Real time detection and reporting of vehicle collision," 2017 International Conference on Trends in Electronics and Informatics (ICEI), Tirunelveli, 2017, pp. 1029-1034.