

Design Requirements of Solar Powered Plug In Hybrid Electric Vehicles

GouthamiEragamreddy^a, Dr. S. GopiyaNaik^b

^aResearch Scholar, VTU, Belagavi,gouthami.erp@gmail.com

^bProfessor, Department of Electrical and Electronics Engineering, PES College of Engineering, Mandyagopiya.naik94@gmail.com

Article History: Received: 10 November 2020; Revised 12 January 2021 Accepted: 27 January 2021; Published online: 5 April 2021

Abstract: The Paper is focused to give the design requirements of SPPHEV (Solar Powered Plug in Hybrid Electric vehicle), which is one of the solution to reduce the air pollution. As transportation in India is mainly dependent on Fossil fuels to drive the vehicle. Installation of Solar panels on the roof top of Electric vehicle is proposed in this paper which helps to adopt the full range electric vehicles in near future. The proposed model is solar powered PHEV (SPPHEV) in which the vehicle battery gets charged with multiple energy sources specifically Power from Photo voltaic (PV), Grid power, Regenerative power and Engine power. Vehicle Control Unit is designed to standardize the flow of power from the energy sources available and also to monitor SOC (State of Charge) of the battery.

Keywords: LGS, mathematics, teacher, difficulty

1. Introduction

Electric vehicles are the emerging research in the field of automobile to reduce the environmental pollution to some range in upcoming days. Electric vehicle technology was available much before Internal Combustion Engine vehicles (ICEV). But ICEV won in the market in those earlier 40's due to their fast running and cheaper cost. Now the focus again turned to electric vehicles as their performance is environment friendly and reduces the air pollution to the great extent. Locomotive manufacturers started R&D of HEV (Hybrid electric vehicles). Transformation from ICE engine based engines to Electric vehicles started by the manufacturers like Tata Motors, Mahindra, Ford, General Motors, Volkswagen etc., [1]. As per the studies, air pollution is increasing in India. Among the various reasons for air pollution, transportation is one among the prominent reason in polluting the air. Carbon Dioxide emissions are more in transportation sector compared to the industrial sector. In transportation sector alone, total energy consumption is around 27% and Carbon emissions are 33.7% [2].

With ever growing concerns on eco-friendly, Electric Vehicles (EV) are propelled a retaliation for transportation. Renewable energy is perceived as the resolution for dealing with both increasing environmental sustainability and electricity demand. The environmental assistances of EV depend analytically on the electricity from which it receives power. Nowadays, EVs shows a favourable technology that depends on fuel costs, vehicle and its attributes such as charging infrastructure costs and driving range. Subsequently, Photo Voltaic (PV) represents time-floating and non-dispatch able energy supply while EVs might denotes energy storage and manageable loads [3,4]. In conventional ICE 40 to 70 % of energy is wasted due to thermal energy to exhaust [5]. The recent trend recommends; EV to substitute ICEV in the near future. EV causes impacts substantially on the power system, environment and other interrelated areas. Power system could face enormous uncertainties with EV penetration. With suitable Coordination and control, EVs can be turned into a chief contributor to the implementation of the smart grid concept successfully. This paper it is proposes a Solar Powered Plugin Hybrid Electric vehicle(SPPHEV) where Battery power source to be utilized in PHEVs using an efficient controller to meet the needs of transportation. In [23] the authors discussed an efficient method to improve the efficiency of wireless charging

Here Section-I is to analyse why SPPHEV is required and the literature on the same. Section-II is giving the inputs of classification of EV, Section III about proposed model and its design requirements, Section IV deals with control strategies and Section V draws the conclusion.

2. Classification of Electric Vehicles

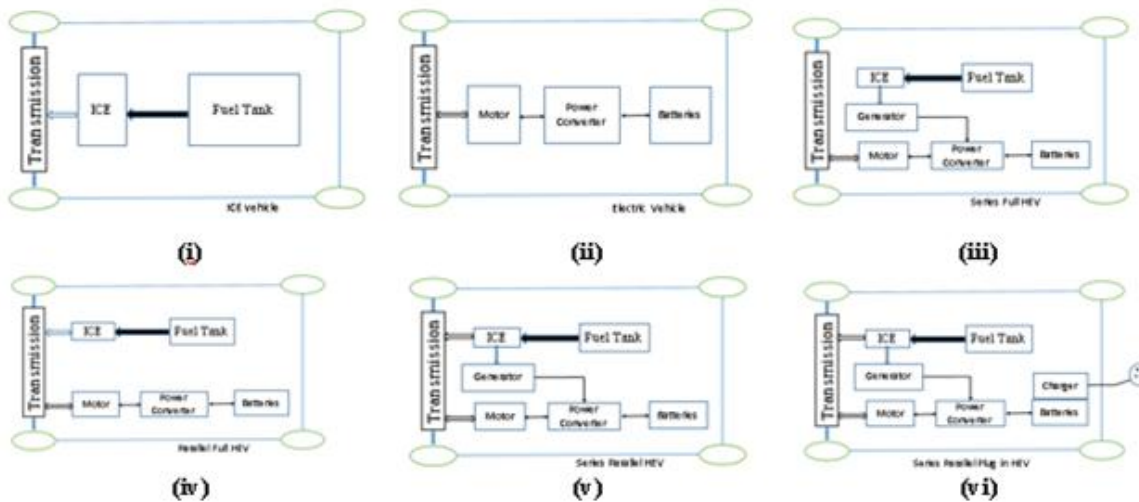

Fig.1i) ICEV ii) EV iii) Series HEV iv) Parallel HEV v) Series Parallel HEV vi) Series Parallel Plug in HEV

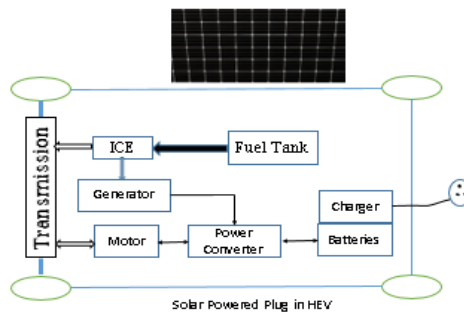

Fig. 2: Solar powered Plug in HEV

As per the existing literature, the electric vehicle utilises one of the energy source as Battery which drive the electric motor. EVs are classified as BEV, HEV, PHEV. Fig .1 shows the working blocks of the vehicles ICEV, EV, HEV and PHEV. The operation of Fig. 1a is ICE engine where the vehicle takes the energy input from ICE. Fig.1b is EV where the vehicle takes the energy input only from battery. Fig. 1c, 1d, 1e respectively represents Series, parallel and Series Parallel HEV where the energy input is from both ICE and Battery. Fig. 1f represents PHEV where the charging of the vehicle takes place with plugin mode. Considering the above models, ICEV is running with Fossil fuels, EV running with battery which gets charged by the Electric supply, HEV runs with ICE and Battery. Table 1 specifies the components used in the design of ICEV, EV, HEV, PHEV and the Proposed SPPHEV. Major modules of HEV are identified as Electric Motors, Batteries, Internal Combustion Engines and the other Support components. The modelled components are to simulate the drive trains like All Electric, Series hybrid and parallel hybrid configurations using MATLAB/Simulink. V-Elph package is the methodology used for Fuel consumption, vehicle emissions and complexity are compared with various drive trains. [6]. Hybrid drive architectures available are Mild and Micro. Micro hybrid is having a battery which powers the auxiliary components of the vehicle.

Table 1: Electric vehicles and their Modules

Module name	Vehicle Type				
	SPPH EV	PHEV	HEV	EV	ICEV
Auxiliary Battery	✓	✓	✓	✓	✓
Charging port	✓	✓	✗	✓	✗
DC/DC converter	✓	✓	✓	✓	✗
Elec generator	✓	✓	✓	✓	✗

V Elec traction motor	✓	✓	✓	✓	✗
Exhaust system	✓	✓	✓	✗	✓
Fuel Filler	✓	✓	✓	✗	✓
Fuel tank(gasoline)	✓	✓	✓	✗	✓
ICE	✓	✓	✓	✗	✓
On board Charger	✓	✓	✗	✓	✗
PEC	✓	✓	✓	✓	✗
Thermal System	✓	✓	✓	✓	✗
battery pack	✓	✓	✓	✓	✗
Transmission	✓	✓	✓	✓	✗
Fuel pump	✗	✗	✗	✗	✓
Fuel injection system	✗	✗	✗	✗	✓
Fuel line	✗	✗	✗	✗	✓
ECM	✗	✗	✗	✗	✓
PV Panels	✓	✗	✗	✗	✗
Charge controller	✓	✗	✗	✗	✗

- Electronic Control Module (ECM)
- Internal Combustion Engine (ICE)
- Power Electronic Controller (PEC)

Mild hybrid uses Battery and ICE but the vehicle depends more on ICE. In Full Hybrid Electric vehicles, the classification comes as Series, Parallel, Series Parallel, Complex full HEV, Series Parallel PHEV [5]. Series Hybrid, Parallel Hybrid, Series- parallel (Power Split) Hybrid are the categories HEV are studied so far. The strategy of minimising the Fuel consumption and maximize power utilizations extends the lifetime of the battery and decreases the fuel consumption. Regenerative braking helps to recharge the battery to some extent during the deceleration of the vehicle. It converts the thermal wastage of the vehicle into rotational energy. Implementing the suitable control strategy helps in controlling the HEV [7]. Speedy revolution of Conventional vehicles to Electric vehicles faces the challenges related to energy sources, enormous load on the grid and concerns in charging of the battery [8]. Hybrid Configuration of plug in BEV with PEM fuel cell is modelled in Fuel cell EV but more safety measures are required to store the hydrogen [9]. Replacement of Gasoline powered ICE is done with PV is considered as PHEV in literature. Small PV module is used on the roof of the car. Battery energy is also used to supply home needs using Vehicle to Grid transfer. Battery of 19.2 KWH and 200W PV module with 1880 Kg vehicle added 13.2 Km of Cruising range of PHEV with speed of 121 Kmph and 91% power efficiency. Literature from [10] proposed Temperature dependent model in EV which says that Effect of temperature change on the motor efficiency is minimal. The proposed model is an extension to plugin HEV. Roof top of PHEV is covered with suitable solar panels to charge the battery when there is solar light availability. In the country like India, existence of sun light is yearlong and fixing solar panels reduces the usage of fossil fuel as well as the electricity bills. So, to overcome the difficulties to some extent the proposed model SPPHEV is shown in Fig. 2.

3. Proposed Model

This section discusses the design requirements of the proposed SPPHEV shown in Fig. 3.

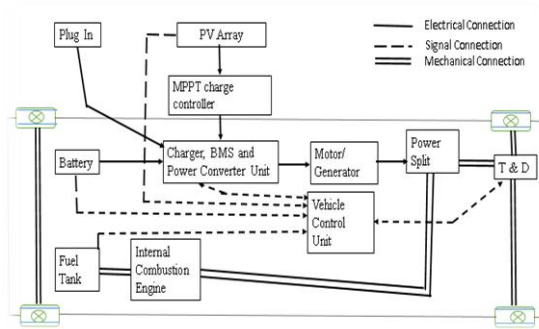

Fig. 3: Block diagram of SPPHEV

Solar Panel unit:

Integrating Renewable energy sources to the plug in vehicles reduces the pressure on grid, pollutant emissions and the cost of the fuel. [2]. Solar panel installation is a challenge due to low space of the vehicle [5]. PV fed HEV and energy storage, Battery Management System (BMS) and power converter topologies are used. Performance and reliability are enhanced. Solar panels are installed on the roof top of the HEV. Proper usage of MPPT technique in the installation of PV panels on roof top of the vehicle enhances the energy generation [11]. Integrating the electric vehicle energy with the residential solar charges the battery with solar energy which reduces the burden on the grid [12]. Grid connected PV, residential EV charger Modes: PV mode and Grid connected mode PV used for household Electric Supply and Electric vehicle. Charger used is V2G and charger uses active power filter to achieve Unity power factor. THD is less than 5%. Energy management can be achieved using DC link voltage regulation and sliding mode control used for regulating the DC link voltage [13]. An Aggregator is used to manage the energy profiles of PV generation and EVs. To manage the Uncertain PV fluctuations, a robust multi-time scale EMS (Energy Management Strategy) used to determine power schedule [14]. To calculate the size of the PV array on roof top, the vehicle dynamics are to be considered. To proceed with the proposed model, the vehicle dimensions are chosen from the existing of Mahindra e20 plus and solar panel dimensions considered from loom solar.

As the roof top of the vehicle is spread by solar panels, below calculations are for calculating size of the solar panel:

Vehicle Specifications:

Length(L)= 3.590m;

Width(W) = 1.575m

Assume 80% of the area.

Area available ($V_{r.a} = L * W * 0.8 = 5.5 \text{ m}^2$)

Solar panel size: L = 0.775m and W = 0.665m

Each panel $P_{max} = 75\text{W}$, $V_{oc} = 22.5 \text{ v}$

and $I_{sc} = 4.52 \text{ A}$

Area of the solar panel (PV Panel_{area})

= $L * W = 0.515 \text{ m}^2$

No. of maximum solar panels fit on roof top

$$= \frac{V_{r.a}}{\text{PV Panel area}} = \frac{5.5}{0.515} = 10 \text{ panels}$$

Battery unit: Battery selection is based on the operation requirements of the SPPHEV. To energize the vehicle, before selecting the suitable battery, calculations related to Power, Energy are required. Specific Energy, Specific Power and Energy density are to be estimated along with the efficiency, Life cycle and production cost. The batteries available for Electric vehicle are Lead acid, Nickel battery, ZEBRA battery, Lithium (Li), Metal air, Ultra Capacitor, Metal air Fly wheel, Hydro carbon batteries. Among Li battery, Li Ion Sulphide (FES), Li iron Phosphate (LiFePO₄), Li Polymer (LiPo), Li ion, Li titanate (LiTiO) are being used in the Electric vehicles. Li ion is having the specific energy of 118-250 (Wh/Kg), Energy density of 200-400 Wh/L, Specific power of 200 - 430 W/Kg, Lifecycle is of 2000 to 3000 cycles, Energy efficiency is more than 95% [5]. Batteries selected in the various electric vehicles BEV, HEV and PHEV are Li-ion, Ni-MH, Li-Polymer [15]. Table 2 gives various battery ranges being used in EV. Battery data represented using Recursive Neural Networks and Multi-channel is

extended with Convolution Neural Networks with vector representation is used to predict the state of charge of the battery [16].

Table 2: Battery types and Ranges used in EV

EV Type	Battery Used	Range of the batteries
PHEV	Li-ion	7.6 Kwh to 18.4 KWh
HEV	NiMH	0.94 KWh to 1.31 KWh
	Li ion	0.75 KWH to 28 KWh
	Li-Polymer	1.6 KWh
BEV	Li ion	16 KWh to 35.8 KWh

Battery capacity is estimated based on the vehicle requirements: distance per charge and speed of the vehicle.

For example: If speed of the vehicle is estimated as 85 km/charge at 45 Kmph and motor with 1458w power, 48V rating

$$\text{Energy consumption per km} = \frac{1458}{45} = 18.21 \text{ wh/km}$$

$$\text{Capacity of the battery per km} = \frac{18.21}{48} = 0.379 \text{ Ah/km}$$

$$\text{Total required Capacity of the battery (Reqd. Capacity)} = K * 0.379 * 80 \text{ km}$$

K is the multiplying factor 1.25 of the battery capacity 20% which is charge left after drive in the battery.

$$\therefore \text{Battery Reqd. Capacity} = 38 \text{ Ah}$$

As per the Li-ion battery datasheet, battery is of 3.7V and 2.5Ah rating.

$$\text{Total no.of cells connected in series} = \frac{48}{3.7} = 13$$

$$\text{Total no.of cells connected in parallel} = \frac{38}{2.5} = 16$$

$$\text{Total cells in li-ion battery pack} = 13 * 16 = 208 \text{ cells}$$

Electric Motor and Engine Selection:

The arrangement of motor and engine is shown in Fig. 4. As the vehicle is PHEV, the combination of EV and ICEV are involved. Both are connected in series and parallel combination with power split.

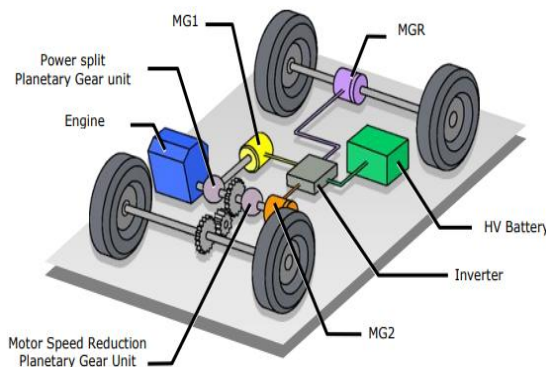

Fig. 4: Arrangement of motor and engine (Toyota Hybrid Synergy)

Electric motor and IC Engine are used along with Power split unit. Electric motor is a motor generator set which functions both as motor and generator in acceleration and deceleration of the vehicle respectively. Suitable motors to the EV are DC Series motor, PMSM motor, BLDC motor and 3-Phase IM. Among all the motors 3 phase IM is the choice in recent days due to the rugged performance and less operational costs.

Vehicle Control Unit:

Controlling of the vehicle varies based on the vehicle power demand, Velocity, SOC of the battery and other parameters. Design of BMS is possible with Power Electronic Devices are achieved with Control Algorithms. BMS design include passive and active methods. Combination of Battery with other energy sources meets the

storage and Peak current characteristics [17]. Control Strategies available for use are Rule based and Optimization approach. Rule based is further divided into Deterministic Rule based method and Fuzzy Rule based method. Model Predictive control based Energy management strategy is implemented for Parallel PHEV. Dynamic Programming is used as algorithm to improve the calculations related to speed, optimal power distribution, battery SOC is considered as the priority [13]. Implementing Intelligent Energy management strategies using the methods like: Data Driven and Principle based. Hybrid Series HEV, Electric Motor is the primary source. Parallel HEV the ICE and Electric Motors both are used to drive the wheels. SPHEV are used in small vehicles which switches the control of driving the wheels among ICE and Electric Motors. Energy management strategies as per the Fuzzy rules are classified as Data driven, Principle based and Composite and they are further classified as Rule based, ANN based, Optimization based, Metaheuristic based, Markov Decision Problem based, Optimized Rule based. [18]. Scheduling of the electric power reduces the production costs, minimizes the emission costs [19]. Iterative Dynamic Programming and Adaptive neuro fuzzy interference are used to obtain optimal control [20].

Power Electronics requirements: Power Electronics Play a major role in the Electric vehicle design. Vehicle Technology is the combination of Mechanical systems, Electrical Systems. Conversion of DC to AC is done by the inverter which runs the 3 phase Induction motor. DC to DC conversion takes place to boost the DC power from the battery. AC to DC conversion is used in the regeneration process [21]. Power electronics is found as the enabling technology to develop environmental friendly vehicle helps in Reducing pollutants and improves the fuel economy [22].

4. Conclusion:

This paper is giving the basic design requirements to build a SPPHEV. Electric vehicles are mainly classified as Series HEV, Parallel HEV, Series/Parallel HEV, PHEV. Existing model electric vehicles are taken as reference to develop the proposed model. The calculations like the area of the roof top of the vehicle for installation of solar panels is calculated. The total number of panels fit on the vehicle roof top are calculated. To run the vehicle with said power rating can be done by usage of the battery. The total charge and voltage rating of the battery pack is calculated and the number of cells required to achieve the battery rating is calculated. Available set of motors suitable to run the EV are acknowledged and chosen the appropriate motor. The detailed mathematical calculations and Simulations are yet to be performed.

References

- Yang, Y., Parten, M., Berg, J., & Maxwell, T. (2000, September). Modeling and control of a hybrid electric vehicle. In Vehicular Technology Conference Fall 2000. IEEE VTS Fall VTC2000. 52nd Vehicular Technology Conference (Cat.No. 00CH37152) (Vol. 5, pp. 2095-2100).IEEE.
- Saber, A. Y., &Venayagamoorthy, G. K. (2010).Plug-in vehicles and renewable energy sources for cost and emission reductions. IEEE Transactions on Industrial electronics, 58(4), 1229-1238.
- Nunes, P., Figueiredo, R., & Brito, M. C. (2016).The use of parking lots to solar-charge electric vehicles. Renewable and Sustainable Energy Reviews, 66, 679-693.
- Coffman, M., Bernstein, P., & Wee, S. (2017). Integrating electric vehicles and residential solar PV. Transport Policy, 53, 30-38.
- Tie, S. F., & Tan, C. W. (2013). A review of energy sources and energy management system in electric vehicles. Renewable and sustainable energy reviews, 20, 82-102.
- Butler, K. L., Ehsani, M., & Kamath, P. (1999). A Matlab-based modeling and simulation package for electric and hybrid electric vehicle design. IEEE Transactions on vehicular technology, 48(6), 1770-1778.
- Panday, A., & Bansal, H. O. (2014). A review of optimal energy management strategies for hybrid electric vehicle. International Journal of Vehicular Technology, 2014.
- Hannan, M. A., Azidin, F. A., & Mohamed, A. (2014). Hybrid electric vehicles and their challenges: A review. Renewable and Sustainable Energy Reviews, 29, 135-150.
- Roda, V., Carroquino, J., Valiño, L., Lozano, A., & Barreras, F. (2018). Remodeling of a commercial plug-in battery electric vehicle to a hybrid configuration with a PEM fuel cell. International Journal of Hydrogen Energy, 43(35), 16959-16970.
- Demircali, A., Sergeant, P., Koroglu, S., Kesler, S., Öztürk, E., & Tumbek, M. (2018). Influence of the temperature on energy management in battery-ultracapacitor electric vehicles. Journal of cleaner production, 176, 716-725.
- Kaleeswari, M., Madheswaran, M., & Vijayakumar, K. (2017, September). Investigation on PV fed hybrid electric vehicles with various power electronic circuits. In 2017 International Conference on Advances in Electrical Technology for Green Energy (ICAETGT) (pp. 49-55).IEEE.
- Wu, X., Hu, X., Teng, Y., Qian, S., & Cheng, R. (2017). Optimal integration of a hybrid solar-battery power source into smart home nanogrid with plug-in electric vehicle. Journal of power sources, 363, 277-283.
- Zhang, Y., Chu, L., Ding, Y., Xu, N., Guo, C., Fu, Z., ...& Liu, Y. (2019). A hierarchical energy management strategy based on model predictive control for plug-in hybrid electric vehicles. IEEE Access, 7, 81612-81629.

- Verma, A., Singh, B., Chandra, A., & Al Haddad, K. (2020). An implementation of solar PV array based multifunctional EV charger. *IEEE Transactions on Industry Applications*.
- Ogura, K., & Kolhe, M. L. (2017). Battery technologies for electric vehicles. In *Electric Vehicles: Prospects and Challenges* (pp. 139-167). Elsevier.
- Zhao, F., Li, Y., Wang, X., Bai, L., & Liu, T. (2020). Lithium-ion Batteries State of Charge Prediction of Electric Vehicles Using RNNs-CNNs Neural Networks. *IEEE Access*.
- Amjadi, Z., & Williamson, S. S. (2009). Power-electronics-based solutions for plug-in hybrid electric vehicle energy storage and management systems. *IEEE Transactions on Industrial Electronics*, 57(2), 608-616.
- Ostadian, R., Ramoul, J., Biswas, A., & Emadi, A. (2020). Intelligent Energy Management Systems for Electrified Vehicles: Current Status, Challenges, and Emerging Trends. *IEEE Open Journal of Vehicular Technology*, 1, 279-295.
- Swief, R. A., El-Amary, N. H., & Kamh, M. Z. (2020). Optimal Energy Management Integrating Plug in Hybrid Vehicle Under Load and Renewable Uncertainties. *IEEE Access*, 8, 176895-176904.
- Fan, L., Zhang, Y., Dou, H., & Zou, R. (2020). Design of an integrated energy management strategy for a plug-in hybrid electric bus. *Journal of Power Sources*, 448, 227391.
- Bellur, D. M., & Kazimierczuk, M. K. (2007, October). DC-DC converters for electric vehicle applications. In *2007 Electrical Insulation Conference and Electrical Manufacturing Expo* (pp. 286-293). IEEE.
- Emadi, A., Lee, Y. J., & Rajashekara, K. (2008). Power electronics and motor drives in electric, hybrid electric, and plug-in hybrid electric vehicles. *IEEE Transactions on industrial electronics*, 55(6), 2237-2245.
- PaideVenkataNarasimhaRao, P. Balasubramanyam S. Muthubalaji. (2020) 'Improving the Efficiency of the Electrical Vehicle Wireless Charging System by Rectifier Load Analysis Using ANFIS Controller " Jour of Adv Research in Dynamical & Control Systems , ISSN 1943-023X, vol12 ,Spl. Issue 3, pp. 1370-1379