

RFID Based Vehicle Toll Collection System for Toll Roads

Piyush Singhal¹, Rajkumar Sharma²

^{1,2}Department of Mechanical Engineering, GLA University, Mathura 281406, India
piyush.singhal@gla.ac.in¹

Article History: Received: 10 November 2020; Revised: 12 January 2021; Accepted: 27 January 2021;
Published online: 05 April 2021

Abstract: The RFID-based vehicle collection program is intended to better handle toll operations through technology that aims to streamline the flow of vehicles. The purpose of this work is to plan, introduce and promote the automated operation of the car selection system (VTS). The Vehicle Toll Collection Device in this paper automatically detects vehicles and gathers machine-readable details on tolls for automobiles driving in the toll road. This knowledge is instigated by the modification and installation of at least one vehicle with a moving vehicle detection device. The computerized control device located along the toll line will transmit the registration signal as the car is reaching the registration point and will determine the toll to be debited and transfer the toll electronically to the account of the individual vehicle. This device helps a car to proceed beyond the scan point with no halting, thereby providing commuters with optimum comfort, speeding up traffic movement and reducing the need for human capital on highways.

Keywords: Auto ID; ETC; RFID; Traffic congestion; Toll; Toll lane; VTS

1. Introduction

A toll road is a route that receives a tax for usage by a traffic agency. Uncertainty in supply chain was presented by [1–6].

Toll bridges and toll tunnels are also open. Taxi cables are crossed through millions of cars every day [1]. A significant amount of metropolitan centers are subject to an rise in population growth, which in the end contributes to a rise in automobile use leading to delays in traffic leading queues during peak hours at main roads [2-6]. The established tunnel, bridge and tower storage facilities contribute to heavy travel, time and fuel consumption and rising air emissions [7, 8]. Passageways were not only not happy with the charge charged on the equipment, but also with excessive delays at the equipment [9-15].

A Modern Automated Toll Collection (ETC) system to increase quality and productivity in the area of road transport was launched to address these issues [16]. In this regard, a modern technology has been implemented. The electronic tax collection (ETC) is a relatively advanced technology that enables highway tolls to be charged online. In the case of the electronic money exchange between a car that goes through a toll station and the toll authority, ETC structures utilizing car-to-road contact technology. ETC programs include OBUs, vehicle identification, designation, and compliance equipment. ETC machinery effectively eliminates a human (or coin machine) by extracting tolls manually at toll booths. It also helps such purchases to be carried out as automobiles ride at a quick driving pace on the highway.

Normal prepaid cards are owned by customers. A simple scheme will have to offer every toll authority a lump amount and to be compensated for any tolls. The VTS in the toll gate decides which cars are licensed, informs enforcers that they are not, and then makes a debit entry of the histories of authorized vehicles electronically with no halting or moving a lock to open. Without halting them.

2. Literature Review

[17] A toll scheme has been introduced by Arthur B. Chiappetti to exclusively support authorized customers. Given automated user authentication, the manual pickup operators are expected to control pickup operations. No forensic documentation is accessible for toll infringers because the toll company will not register the toll infringers' numbers plates. 'Patent for the collection of highway service by Bernard N. Riskin and Lambertville N.J.' Patents [18] established a Bar Code Authentication to receive tolls. This method is somewhat close to the systems under which a payment card program is utilized. However, in contrast to RFID, the bar code system is in some weaknesses, such as a visible line limitation and poor reading ability. The fundamental elements of the payment process, a digital interchange with an automotive travelling via a toll station and the payment company, and the information acquired through the service network can be seen in a technical study from Dimitri Loukakos [19]. Dwaine S. Hutra and Francis B.Fraze [20] identified the method of recording the transaction between the car and the toll authorities in the 'Transactions Accounting on Toll Transactions in Transponder Systems.' This effort is an excellent feature for deciding if the report was skipped or multiplied. The collection of

tolls is feasible via the transponders of Fred Slavin and Randy J. Schafer [21], who have pre-determined sum of prepayment by way of their patent called 'Toll collection program.' A standard Prepaid Card has been set up for the customer by the car transponders and the card will be periodically refilled. The 'Elektronic automobile toll collection device' and the method fuel tax collection program by John J. Hassett [22] have two sections: the automobile toll processor and the toll recognition machine that automatically deducts the prepaid tax on effective car detection. A technology has been created by Hironao Hayashi and Tomoyuki Watanabe [23] that can interact with vehicles and roads. It includes vehicle hardware, a road communication system and a storage element that is necessary if a communication accident happens. Hiroyoshi Sekine [24] developed a radio cards toll collection device that transfers the identification number of the vehicle. The camera built on the toll line has recorded the picture of compare vehicle sum with the number plate data on the count plate and toll processor. Howard A. Baldwin et al. [25] designed a remote recognition system of objects in movement. Matt Ward [26] explained the profound discovery of RFID technology, providing basic aspects such as RFID building blocks, frequency of use and implementations. For pre-paid car consumers, Norman E.Chasek [27] used microwave technical toll collection. The prepaid invoice is placed in a transponder buffer which is installed on cars and credited with a good balance of the cars. The tone for negative equilibrium is created and the vehicle for toll collection halted. With the help of the parameters describing the mail number in relation to the road segment of a road network by using a vehicle location tool, Robert Schuessler [28] finds a method of calculating cars toll. The tax on automobiles relating to the distance covered by this process is determined. Essential application in payment methods of RFID technology, Smitha Ramachandran [29] reported. It also discusses the benefits of "RFID, contactless payments and the way the RFID manages contactless payment".

Consequently, an effort was made to establish a Vehicle Toll Scheme based on RFID. The research found in this paper is a tool for the collection of prepaid vegetable tax for prepaid customers, and may assess and deduct a toll by means of RFID, by means of a device for the detection of toll infringements and Digital camera machine unrepaid customers. The program also enables the prepaid to be obtained. The control unit operates for the marking of number plates.

In addition to grown nations, many toll roads have a gate that is operated manually or automatically in certain situations. In this manual, an engine-and-limit transition involves a function controlled by a button. This program contributes to continuous problem free travel on toll roads by rising wait, congestion and fuel usage, emission of cars, handling and air emissions, and supplying travelers with optimum comfort and enhanced toll audits.

3. Vehicle Toll Collection Systems

This program consists of many control mechanisms intended to resolve the limitations of the existing network of toll collections. The program depends on four main elements, Automatic Vehicle Detection and Infringement Analysis (AVI) and Automatic Vehicle Classification. The following parts address each part in depth.

3.1. Automated Vehicle Identification (AVI)

The way to determine the identity of a car subjective to charges is automatic vehicle recognition (AVI). This is then the job in the gate area to locate the car. Any early AVI schemes used bar codes for each vehicle for optical reading at the mailing stand. Optical systems have shown low readability, especially in the face of bad weather and dirty automobiles. This article favored the RFID-focused AVI systems, where an antenna is communicated to the car transponder through a DSRC at the mail gate. RFID tags are proven very accurate and can be interpreted at road speeds. This paper is based on RFIDs.

Identification of Radio Frequency (RFID)

RFID is a general term utilized to define the device that uses radio waves, wirelessly conveys the identity of the item (as a specific serial number). It provides greater versatility, higher storage space, improved data collection efficiency, and more rapid selection and precision. Radio frequency is no optical infrastructure and does not include the transmitter-receiver site axis. This is an essential aspect to differentiate between RFID and the bar code and other auto-identification systems.

ETC system commonly utilizes Radio Frequency Identification (RFID) technology. RFID is a generic term utilized to find technologies that use radio waves for automatically identifying humans or objects [3]. RFID technology was first proposed in 1948 when Harry Stockman published an article examining RFID technology

titled, “Communication by Means of Reflected Power” [4]. RFID technology has made huge progress since then, and has been realized in different applications like warehouse management, library system, attendance system, theft prevention, etc. Generally, RFID is helpful for the tracking, tracing, and identification of objects.

RFID is an automated data-capture technology, which can be employed for electronically identifying, tracking, and storing information present on a tag. A radio frequency reader performs the scanning of the tag for data and passes the information to a database, which then saves the data present on the tag. An overall RFID system includes a transponder (tag), reader/writer, antenna, and database.

RFID: Tag The transponder, better called as tag, is a microchip integrated with an antenna system in a portable package. The microchip has memory and logic circuits to receive and then send data back to the reader. The antenna attached to the microchip helps in the information transmission from the chip to the reader. Generally, a larger antenna stands for a bigger read range. The tag is fixed to or implanted in an object so that it can be identified, like a product, case, or pallet, and can be scanned using mobile or stationary readers with the help of radio waves. Fig 1 shows the RFID Transponders (Tags)



Figure 1. RFID Transponders (Tags)

These tags are categorized to be either active or passive tags. Active tags include internal batteries, which permit for a bigger reading range, whereas the power for the passive tags are obtained from the signal coming from its reader and therefore their reading range is smaller. Tags could also be categorized on the basis of the content and format of information. A chip can save a distinct serial number or other information depending on tag's kind of memory, which could be read-only, read-write, or write-once read-many (WORM). The range of classifications are from Class 0 to Class 5. These classes have been decided using the Electronic Product Code (EPC) Global Standard.

RFID Reader: For an RFID system to work, a reader, or scanning device are required, with the capability of robust reading of the tags and then passing the results to a database. A reader has its own antenna for having communication with the tag. An antenna is utilized for transmitting and also receiving data from the tag. When a reader propagates radio waves, all tags made to react to that frequency and lying within the range will send a response. A reader is also capable of communicating with the tag with no direct Line-of-Sight, based on the radio frequency and the kind of tag (active, passive or semi passive) utilized. The reader also has a decoder and an RF module. Readers can help processing several items at once, permitting for improved read processing times. It could be attached or fixed as a compact hand held device. They can be mobile, like portable devices, which are used in objects scanning such as pallets and cases, or stationary, including point-of-sale devices employed in supermarkets. Fig 2 shows the RFID reader.



Figure 2. RFID Reader

3.2. Automated Vehicle Classification (AVC)

The Automatic Vehicle Recognition (AVI) is directly linked. Most tax facilities charge specific tariffs for various vehicle forms, so that the vehicles which pass through the toll network must be differentiated. The best approach is to report the car class and make use of the AVI details to search for the car type, which has been shown to be an economic route. For the information of the automobile from the centralized network the planned VTS program uses the identification symbol. A camera can also be attached to a toll lane to take a photo of the vehicle number plate to check that the actual image of the vehicle suits the registered photo number plate with that identifying code.

3.3. Transaction Processing

Transaction management includes acts, such as business accounts managing, shipping toll transfers, consumer account fees and customers' demands. Transaction management Customer balances would be prepayment as consumers finance an account balance that is exhausted as peak purchases take place. The prepaid balance is displayed to the driver through the monitor in the automobile in our system. The negative balance is seen by the stationary control unit sound. Because they are both computerized and work with payroll cards, the toll is correctly received and in a particular form.

3.4. Violation Enforcement

The Infringement Compliance Program (VES) should be utilized to reduce overdue tolls, since otherwise an unpaying toll door is an enticing target for dodging toll. The Camera Deployment Program (VES) takes pictures of license plates of cars traveling without a proper tag via the toll booth. A lot of the prior equipment for camera management applications involved photography and video processing devices, all very hard working.

Video-based video image cameras are the newest tool utilized to take license plate pictures of violators of the toll. Digital photography enables the recording, online storage and transfer of photographs to distant areas. The tool automatically reads plates at highway speed all 24 hours a day and all seven days a week. The traffic control plate is registered on either lane or on the side of the road in less than 0.25 seconds. This app presents state and country details in addition to the license plate number; it can even link a list of authorized users for each possibly infringing plate number.

4. Elements of VTS

Two systems are given for the vehicle buying program, the Mobile and the Stationary Unit. The mobile device is placed on the vehicle and the identifying information is given. The control device is situated next to the toll road. The heart of the auto payment program is this. The database also requires a host machine. Both lane devices are easily linked to the central device. Thus, even though they are special, the toll is received and passed to the applicable tax collection agency. The two components are explained in depth below.

4.1. Mobile Unit at Vehicle

This is VTS's first development unit. The AVI cycle starts the task of this machine. The balance is often seen after the accrued sum has been debited by the levy. Figure 3 demonstrates this handheld transmitter's simple block diagram.

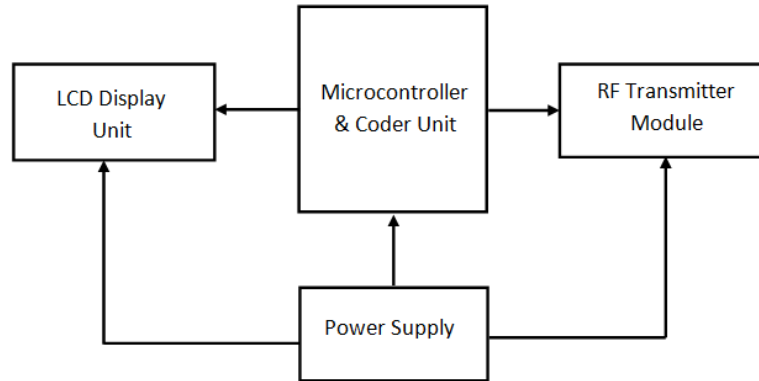

Figure 3. Car control device

It includes the RF board, Micro-Controller-Coding and LCD package. The RF module produces the RF signal at a different frequency and the distinct code is the “Microcontroller Coder” for each car. This special code is the RF-modulated keys of the amplitude change and transmitted through the RF antenna. 2n vehicles may be marked if the code includes 'n' bits. The meaning of 'n' and the Microcontroller coder is then chosen according to the number of vehicles. The radio frequency is chosen accurately so that no other programs will disturb. Per nation has its own collection of defined frequencies. The frequency should be carefully chosen when developing the RF module. The balance shall be reflected in the LCD panel. The control package is configured in order to adjust the power level by the cell phone taken from the car battery.

4.2. Stationary Control Unit

The control stationary starts from the antenna RF mounted on the toll road. The mobile vehicle receives the RF signal. The customer is checked for the prepaid and the fee is charged. The tax is then drawn out of the customer's lump sum and the remainders are transferred to the driver by the LCD unit on the mobile vehicle. Furthermore, the gate circuit is powered by drivers who can pay the fee enough.

There is a display panel indicating the driver balance and the operation of the door opening or closing. If the balance is negative, alert is generated and the door is not opened. After the driver charges the toll in the same time, the driver has zero reserve, so only once an alert tone is formed. The block diagram of this stationary unit is given in Figure 4.

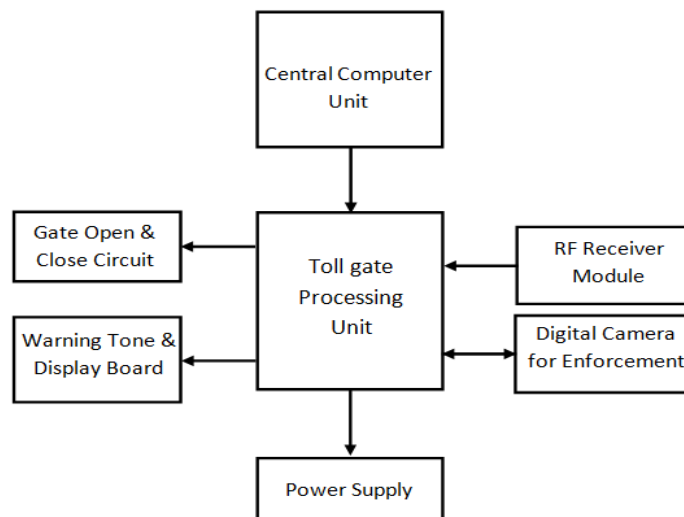

Figure 4. Control Unit Stationary

The camera unit shall conduct the operation of the breach. It captures and sends the vehicle's image to your host computer system on the license plate. It is used to identify cars which try to escape. As reported, if the customer is not paying in advance or has negative balance, the driver does not open up. The driver can go through the toll area and reach the gates. The camera unit is used to identify and prosecute him. The circuit of the door contains different construction blocks: relays, limit switches and an engine.

There are three parts to the open / close door circuit. The following are the parts and workplaces.

Elements switching: Relaxation is used as elements to switch. In this circuit there are two relays. There is no movement when the two relays are opened or closed. For the following operation, the only relay for the forward direction is closed while the other is for the opposite direction closed.

- Advance open circuit switching
- Closed circuit reverses flipping

Limitation Switches: Used for sensing the end of door service and the stops the engine.

Transfer Diodes: the motor rotates in the opposite direction with the help of these diodes.

5. Working of VTS

It takes a couple seconds for the whole cycle to end. The two modules are half duplexed. The link between the two modules is shown in Figure 5. The contact takes place here from both sides but not at the same moment. The handheld portable device first sends the details regarding identification. After debiting, the stationary control unit gives the drivers the balance, the toll from the pre-paid number.

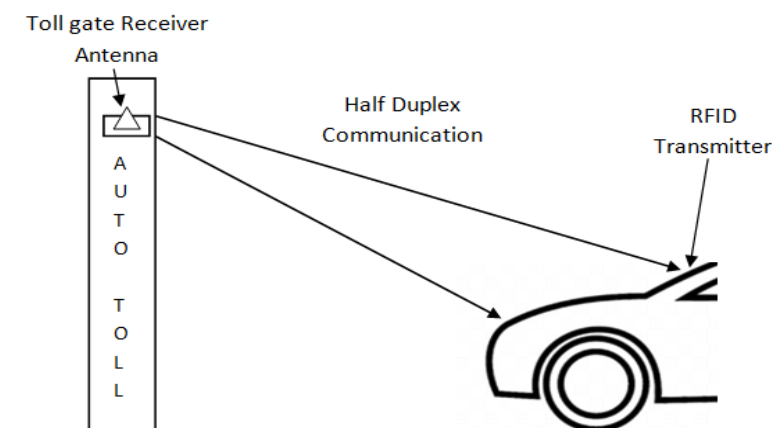

Figure 5. Car and Gift Receiver contact.

The points below explain how the whole process is performed.

- i The Mobile Vehicle unit sends a signal with some basic information on the lane antenna as a car comes near to a toll plaza.
- ii The data is transmitted to the central database from the lane antenna.
- iii Identification of license plate is carried out, and the account location checks when the positive result is obtained. Simply opening the door does not happen because it will not yield the desired outcome.
- iv If the record is well formed, the tax shall be removed on or after the prepaid driver's check and the toll lane door shall unlock.
- v If, after debiting the fee, the account has zero balance and a alert tone is generated the gate is opened once.
- vi The gate is not unlocked, and the alarm tone is generated for negative balancing clients.
- vii SMS which say drivers about their balance of account and the gate functioning in the display board.
- viii The device will monitor the driver and take a screenshot from the licenses plate whether he or she is not a prepayment holder or has a negative balance. Otherwise, the car owner may submit an infringement notification via phone.

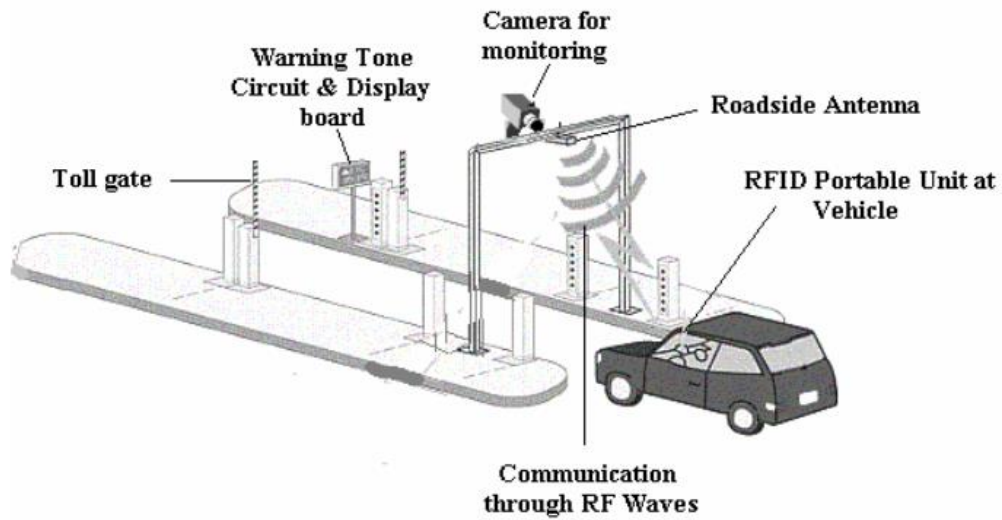

Figure 6. Flow diagram for the whole process

Figure 6 shows the flow diagram for the whole process. The electronic system records every transaction in the toll, which includes the time, date, and plaza and toll payment of every vehicle. Flowchart for the full process is also shown in Figure 7.

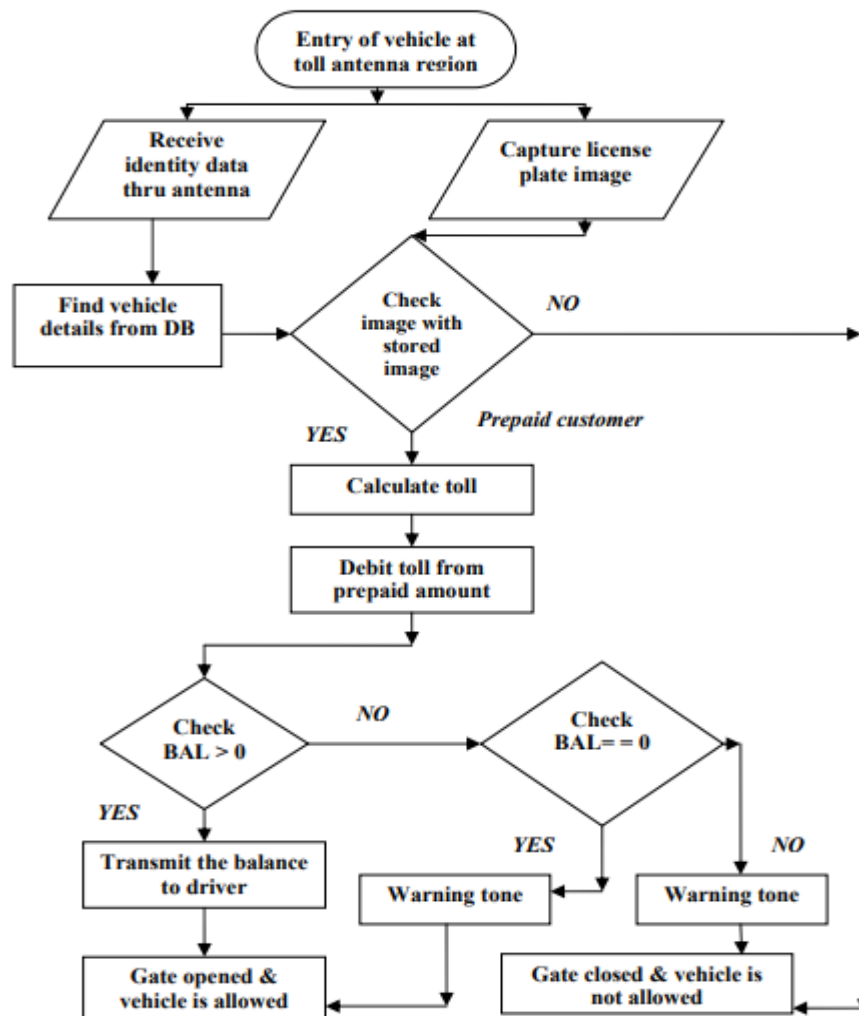

Figure 7. Flow Chart for the whole process

6. Benefits of VTS

There are other critical advantages of this new VTS. The rewards are divided into three aspects: consumers, the tolling authority and culture. On behalf of the consumer, below gives a compilation of VTS advantages,

- i This VTS induce an overall reduction in car waiting time at the toll square, and since waiting periods decrease, traffic congestion will be decreased almost automatically. And that makes the toll customers as convenient as possible.
- ii Pollutants from motor vehicles are minimized, as speeds are raised throughout the toll square and thus fuel savings are gained when traveling without breaks.
- iii The expense of handling the toll transfers will theoretically be minimized. Thanks to the distributed method, prices for human capital are significantly decreased.
- iv It simplifies accounting systems and enhances audit oversight by centralizing user accounts by consolidation of toll collection and vehicle counting.
- v The accurate and efficient detection of toll violators can be accomplished through automated plate recognition systems.
- vi As the vehicle's emissions are reduced, the vehicle's toxic gases have decreased. The air quality is now more easily regulated.
- vii Online, the exchange takes place here; it ends in non-paper bills. This greatly decreases the natural capital needed for the manufacture of paper.

7. Result and Discussion

The results are implemented in Software requirement Framework: .NET 3.5 Software Package: VISUAL STUDIO.NET. 08 Language for Development: C# .NET Database: SQL Server 2008.

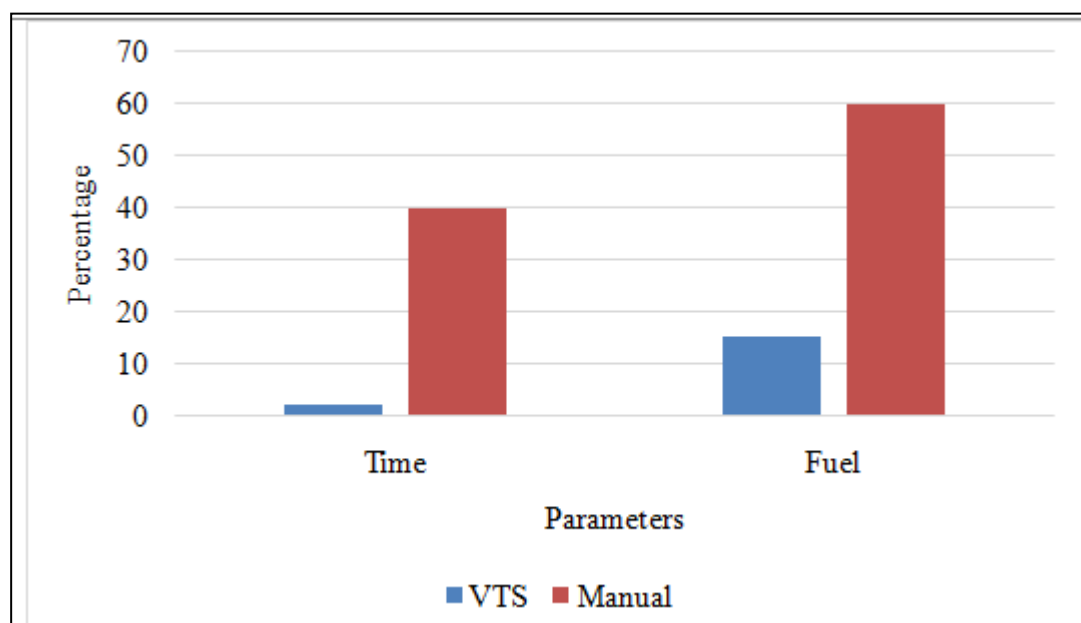

Figure 8. Analysis Graph

Figure 8 illustrates the analysis graph of the discussed scheme. The proposed automatic system performs better when compared with the manual one.

8. Conclusions

The accumulation of dollars on toll roads is more complex and complicated as the organism is that. The creation of a car collection network with the assistance of new technology is the priority of several developing countries. The key aims of the proposed scheme are to minimize traffic congestion and, especially through elimination of the need to avoid paying via the RFID, the seamless movement of vehicle via toll gate. A wireless communication between a wireless antenna installed at the toll door and the transmitter is available. The device planned can be run under all weather environments, and is fairly successful. It lowers tax rates and promotes the

flow of assets. The network also contains such aspects as minimized toll and traffic emissions, time saving and car fuel prices.

References

1. V. Kumar, R. Sharma, P. Singhal, Demand Forecasting of Dairy Products for Amul Warehouses using Neural Network, *Int. J. Sci. Res.* (2019). www.wikipedia.com.
2. S. Garg, R. Sharma, P. Singhal, Forecasting of Demand for Small Medium Enterprises Using Fuzzy Logic, *Int. J. Sci. Res.* (2019). www.ijsr.net.
3. A Kumar, K Sharma, AR Dixit A review of the mechanical and thermal properties of graphene and its hybrid polymer nanocomposites for structural applications, *Journal of materials science* 54 (8), 5992-6026.
4. K Sharma, M Shukla, Three-phase carbon fiber amine functionalized carbon nanotubes epoxy composite: processing, characterisation, and multiscale modeling, *Journal of Nanomaterials* 2014
5. K Sharma, KS Kaushalyayan, M Shukla, Pull-out simulations of interfacial properties of amine functionalized multi-walled carbon nanotube epoxy composites, *Computational Materials Science* 99, 232-241
6. A Yadav, A Kumar, PK Singh, K Sharma, Glass transition temperature of functionalized graphene epoxy composites using molecular dynamics simulation, *Integrated Ferroelectrics* 186 (1), 106-114
7. PK Singh, K Sharma, Mechanical and Viscoelastic Properties of In-situ Amine Functionalized Multiple Layer Graphene/epoxy Nanocomposites, *Current Nanoscience* 14 (3), 252-262
8. Goyal, M. and B. Gupta, Analysis of shape, size and structure dependent thermodynamic properties of nanowires. *High Temperatures--High Pressures*, 48.2019.
9. Goyal, M. and M. Singh, Size and shape dependence of optical properties of nanostructures. *Applied Physics A*, 2020. 126(3): p. 1-8.
10. Singh PK, & Sharma K, Molecular Dynamics Simulation of Glass Transition Behaviour of Polymer based Nanocomposites, *Journal of Scientific & Industrial Research*, 77 (10)592-595 (2018).
11. MK Shukla, K Sharma, Effect of carbon nanofillers on the mechanical and interfacial properties of epoxy based nanocomposites: A review, *Polymer Science, Series A* 61 (4), 439-460
12. A Kumar, K Sharma, AR Dixit, A review on the mechanical and thermal properties of graphene and graphene-based polymer nanocomposites: understanding of modelling and MD simulation, *Molecular Simulation* 46 (2), 136-154
13. K Mausam, K Sharma, G Bharadwaj, RP Singh, "Multi-objective optimization design of die-sinking electric discharge machine (EDM) machining parameter for CNT-reinforced carbon fibre nanocomposite using grey relational analysis, *Journal of the Brazilian Society of Mechanical Sciences and Engineering*" 41 ...
14. MK Shukla, K Sharma, "Improvement in mechanical and thermal properties of epoxy hybrid composites by functionalized graphene and carbon-nanotubes", *Materials Research Express* 6 (12), 125323
15. K Kumar, K Sharma, S Verma, N Upadhyay, "Experimental Investigation of Graphene-Paraffin Wax Nanocomposites for Thermal Energy Storage, *Materials Today*": *Proceedings* 18, 5158-5163
16. Arthur B. Chiappetti. 'Toll collection system', , US Patent No: 4,338,587.Jul 6, 1982
17. Bernard N. Riskin, Lambertville, N.J. 'Method and means for collecting Highway Tolls', USPatent No: 4,555,618.Nov 26, 1985
18. Dimitri Loukakos, 'Electronic Toll Collection', http://www.calccit.org/itsdecision/serv_and_techElectronic_toll_collection.html.
19. Dwaine S. Hutra, Francis B. Frazee. 'Transaction accounting of toll transactions in transponder systems', US Patent No: 6,725,202. Apr 20, 2004
20. Fred Slavin, Randy J. Schafer. 'Toll collection system', US Patent No: 5,819,234.Oct 6, 1998.
21. John J. Hassett. 'Electronic vehicle toll collection system and method', US Patent No: 7,012,547 B2. Mar 14,2006.
22. Hironao Hayashi, Tomoyuki Watanabe. 'On-Vehicle device for road tollcommunication', U.S. Patent No: 5,777,565. Jul 7, 1998.
23. Hiroyoshi Sekine. "Toll collection system for a vehicle", US Patent No: 5,204,675. Apr 20,1993.
24. Howard A. Baldwin, William K. Brockelsby, Conrad M.R. Walker. 'Electronic Identification system', US Patent No: 4,937,581. Jun.26, 1990.

25. Matt Ward, 'RFID: Frequency, standards, adoption and innovation' in JISC Technology and Standards Watch, May2006, http://www.jisc.ac.uk/uploaded_documents/TSW_0602.pdf.
26. Norman E.Chasek. 'Universally applicable, In-motion and automatic toll paying system using Microwaves', US Patent No: 4,303,904. Dec. 1, 1981.
27. Robert Schuessler. 'Device for determining road tolls', US Patent No: 5,864, 831.Jan 26, 1999.
28. Smitha Ramachandran, 'REID Technology and the Payment Process Systems', Feb 2006, <http://202.131.96.59:8080/dspace/bitstream/123456789/85/1/2.03+RFIDTechnology.pdf>.

Biographies



Piyush Singhalis working as Professor & Head (Department of Mechanical Engineering) at GLA University Mathura. His research interest is in the area of Supply Chain Risk Management, Data Driven Modeling and Decision Support Systems. He has published around 50 peer reviewed research papers in renowned journals like International Journal of Business Science & Applied Management, Industrial Engineering and Engineering Management (IEEM). He is also a life time member of Society of Operations Management. He has been awarded his Ph.D. from MNIT Jaipur. He has organized many conferences and workshops at GLA University Mathura. He is also a reviewer of many renowned journals. Recently GLA University has been accredited with 'A' Grade by NAAC under his assistance and direction. Apart from that many students have completed and some are still pursuing their PH.D./M.Tech under his guidance and supervision”.



Rajkumar Sharma is working as an Assistant Professor in Department of Mechanical Engineering at GLA University Mathura. His research interest is in the area of Industrial Engineering. He has completed his graduation in first division from NIT Raipur and post-graduation M.Tech. (Design Engg.) with honors from GLA University Mathura. Currently he is pursuing his Ph.D. in the area of supply chain management from GLA University Mathura. He has published around 15 peer reviewed research papers in renowned conferences held at IIT's & IIM's till date. He is also a active member of Alumni Association of GLA University. He has been awarded LEAN SIX SIGMA YELLOW BELT from Ministry of Micro, small & medium enterprises. He is also having online certification from NPTEL and also awarded with an online digital badge by AUTHORAID available at <http://moodle.inasp.info/badges/badge.php?hash=1ae69d27e7267d1f528d8696dd637a7016b20147> with certificate of merit. Apart from that many students have completed and some are still pursuing their M.Tech/B.Tech project research work under his guidance and supervision”.