

ENHANCING POWER QUALITY IN DC SYSTEMS WITH UPFC-BASED MULTILEVEL CASCADE CONVERTER

¹V. Rajesh, ²Dr. D. Srinivas, ³P. Srinivasa Rao, ⁴Ganji Swathi

^{1,3}Associate Professor, Department of EEE, G V R & S College of Engineering & Technology, Guntur, AP

²Professor, Department of EEE, G V R & S College of Engineering & Technology, Guntur, AP

⁴Student, Department of EEE, G V R & S College of Engineering & Technology, Guntur, AP

Abstract— Mixture Although renewable energy is a good substitute for conventional energy, connecting it to the grid can provide new difficulties. Similarly, for wind turbines to keep the grid stable and reliable, they need to provide high-quality electricity. To reduce the harmful environmental effects of conventional energy generation, more wind turbines are being connected to the electrical grid. Understanding how disturbances impact the quality of the energy is important in order to connect a wind turbine to the grid. The voltage and frequency must be as stable as feasible. This stability may be obtained using FACTS devices. Inverters that are either voltage-source or current-source have been used recently to reduce oscillation in the power supply. Moreover, several of them are used to improve the transient and dynamic stability of wind power generating systems (WPGS). When a wind turbine is linked to the grid, it produces electrical switching behaviour, voltage sag and swell, flashing and harmonic emissions, and active and reactive energy. A three-phase grid-linked wind-driven induction generator's reactive power need may be adjusted in a number of methods, such as by applying instantaneous pq theory and UPQC to adjust for harmonics produced by a non-linear load connected to the PCC. MATLAB/SIMULINK is used to simulate the FACTS Device UPQC control mechanism in order to improve power quality.

Keywords: PCC, Induction Generator, Stability, Dynamic Stability, UPQC, FACTS.

I. INTRODUCTION

In recent years, electrical engineers have focused on power quality as one of the most essential issues. Harmonic distortion and reactive power compensation are the two most important issues in power quality today. The majority of industries and businesses seek high quality electrical energy.

Microcontrollers, computers, motor drives, etc. be destroyed if the energy given to these loads is of insufficient quality. In companies that deal with information technology systems, the damage caused by this phenomenon is severe. For this purpose, Custom Power devices are now employed in most cases, the sole means of filtering harmonics and compensating reactive power at the factory level was to employ capacitors and passive filters. For motor control, modern PWM-based converters are able to deliver power factor operations close to unity. These harmonics cannot be filtered out by this capacitor. We are doing research on Active Power Filters and less polluting drives because of this. An APF in shunt with the load can efficiently compensate for current sources such as diode bridge rectifiers (DBRs) or thyristor bridges feeding highly inductive loads (HILs) at the point of common coupling (PCC). "Harmonics" is an acronym for "harmonics". Perfectly pure voltage and sinusoidal current waveforms would be considered power quality in an ideal world. The design of commercial and industrial power systems must consider power quality. A perfect sinusoidal waveform is ideal. As a result of harmonic distortion, the current or voltage waveforms are deviated from their ideal form. A number of factors could lead to this harmonic distortion. Engineers today place a high value on finding a way to eliminate harmonic distortion. Back when power systems were designed simply and conservatively, harmonic distortion was little. Harmonic distortion, on the other hand, has developed in recent years due to the employment of complicated designs in the industry. There are several ways to lessen the effects of Harmonics in the Power System, and this project explains how to do just that! Harmonic distortion is one of the most critical difficulties linked with power quality, and it causes many disturbances to the power system. It comprises harmonic reduction strategies to improve power quality, as well as a simulation of the same for those procedures.

II. LITERATURE REVIEW

It's no secret that our technological world relies heavily on the availability of electrical power. Almost all countries provide commercial power through national grids, which connect a large number of power plants to the loads. In addition to basic national necessities such as lighting, heating, refrigeration and air-conditioning, other sectors such as government, financial, and commercial sectors, along with medical care and communication must also be served by the grid. In today's fast-paced world, commercial electricity is necessary to keep up. As a result of its tens of thousands of miles of transmission lines, the commercial power system is a major source of power outages. Keep in mind that many of the power problems affecting today's sophisticated technology are caused by local conditions

within a facility. People are becoming more concerned about power quality as electronics are employed in everything from domestic appliances to large and expensive industrial processes. An electrical power quality disturbance is any change in voltage, current or frequency that disrupts the normal operation of electrical equipment. It's not just electric utilities that are interested in investigating power quality and strategies to control it. Even minute variations in power supply voltage, current, and frequency can cause equipment to malfunction, which has prompted more attention to be paid to power supply issues.

Electric power quality refers to how much the consumption and supply of electric power impacts the functioning of electrical equipment. Power quality isn't defined in a consistent way. Utility and consumer viewpoints on electricity quality can be assessed from two different angles when looking at the utility metre. Now, PQ has been redefined. Ideally, an ideal power supply would be one that is always available, within voltage and frequency constraints, and has a pure, noise-free sinusoidal waveform... The capacity of utility companies to provide uninterrupted electricity is hence power quality.

III. CONCEPTS OF FACTS

A. Introduction to Power Quality:

In electrical engineering, power quality refers to the set of electrical attributes that must be met in order for electrical systems to function as intended without significant performance or life degradation. An electrical load's ability to perform properly with electric power is described by this word. It's possible that an electrical equipment (or load) won't work properly if it doesn't have enough power. Electric power can be of low quality in a variety of ways, and there are a number of reasons for it to be of bad quality. Power generation, transmission, and distribution are all part of the electric power business. It then passes through the end user's wiring system until it reaches the load, where it is subsequently used. There are many opportunities for quality of supply to be compromised due to the complicated infrastructure used to transmit electric energy from the point of production to the site of consumption as well as variations in weather, generation, demand, and other factors. The term "power quality" is used by many, however it describes the quality of voltage rather than power or electric current. Current demand by a load might be unpredictable because power is simply energy flowing.

B. Transient Problems:

Sub-cycle transients have short duration and amplitude. Many people think of transients as tens of thousands of volts coming from a lightning strike that destroys anything in its path. There are a variety of factors that might create transients, such as equipment failure or weather phenomena like lightning. Even low-voltage transients can cause damage to electrical components if they occur at a high enough rate of repetition. Protecting yourself against the destructive effects of high voltage transients is frequently as simple as installing a properly sized industrial-grade surge suppressor. SAG: Sagging in the United States is called "sag," while "dipping" in the United Kingdom is called "dipping." The great majority of power problems faced by end customers are caused by sags. An end-user facility can create them both internally and externally. For the most part, external causes are the utility transmission and distribution system. There are many reasons why utility equipment sags, including lightning, animal and human behaviour, and routine and abnormal utility equipment functioning, among many more. Many consumers can be affected at once by transmission or distribution system sags. Other adjacent consumers can induce sags that are externally caused. Start-up of high electrical loads or the disconnection of shunt capacitor banks can cause a localised sag in voltage. A relatively minor amplitude sag can be damaging to the end user who is already suffering from chronic undervoltage. Internally generated sag is often created by the initiation of high electrical loads, such as a motor or a magnet, within the end user's facility. Starting such loads requires a lot of current, which reduces the voltage available to other equipment that shares the same electrical system. Internal sags will be amplified by prolonged undervoltage, just as exterior ones are.

C. Types of Facts Devices

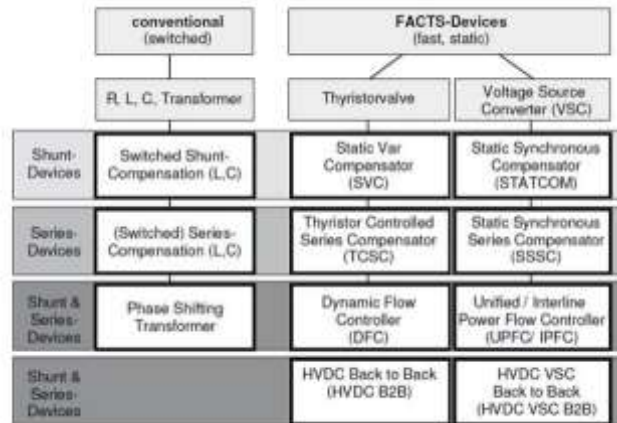

I. PROPOSED CONCEPT

Power quality challenges are raised when wind power is integrated into the grid, such as voltage regulation and reactive power compensation, among others. When used as a power generator, Induction Machines are most commonly found in wind farms. Induction generators are powered by the grid. Due of this, one of the main concerns of power system engineers is how to integrate wind energy into the grid's power distribution system. Adding wind power to the grid has an impact on the quality of the electricity. Power electronic technology has been assisting in the integration of wind energy into the electric grid for a number of years. Numerous non-linear loads exist on power systems. Since switching multiplies power supply frequency, current in these systems consists of several frequency components. Consequently, the current waveform is modified from a sine wave to a new one, and harmonic currents are added to the original (fundamental frequency) AC current. For reactive power compensation in power systems, the most typically employed units to account for reactive power are synced condensers or shunt capacitors (SVC). Reactive power is proportional to voltage squared as a result of this. As a result, the capacitors' reactive power rapidly decreases as the voltage declines. Reactive Power Compensation and Harmonic Reduction are two areas where STATCOM excels at solving problems. The system is built around a voltage source converter (VSC). Because of its ability to alter its output power in accordance to the grid voltage, it can be used as a generator or an absorber of reactive power System block diagram for gridconnected systems (Fig.3.1) On a non-linear load, this generator has been demonstrated with three stages of separately energised induction. To compensate for the reactive power requirements of the induction generator and the non-linear load, a STATCOM is linked to this system at its point of common connection

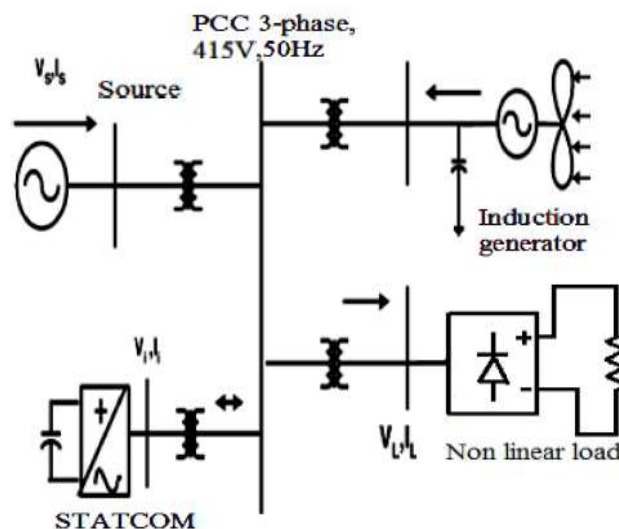

Fig.1: Schematic Diagram of Grid Connected Wind Energy System

STATCOM's proposed control plan for grid-connected wind energy generation covers the following objectives to

improve power quality: So that the wind generator and load have the same power factor, it is required to provide them with the reactive power that they need. Unwanted harmonic effects can be caused by non-linear loads and must be avoided.

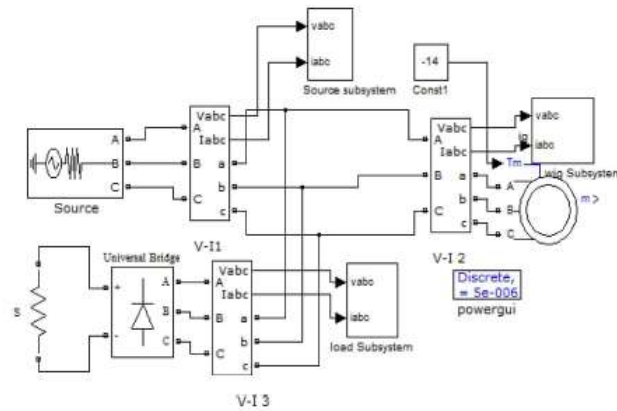

Fig.2: Separately Excited Induction Generator Feeding Non-linear loads

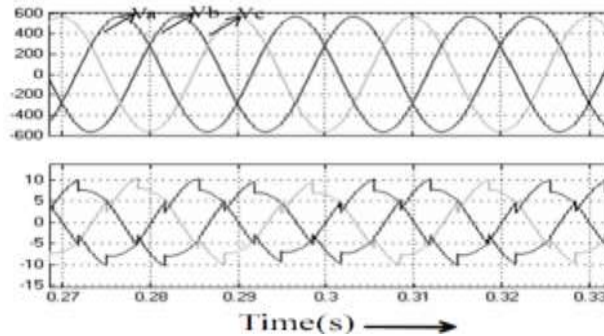

Fig.3: Instantaneous Value of Grid voltage and current for Grid connected system with non-linear loads

II. SIMULATION RESULTS

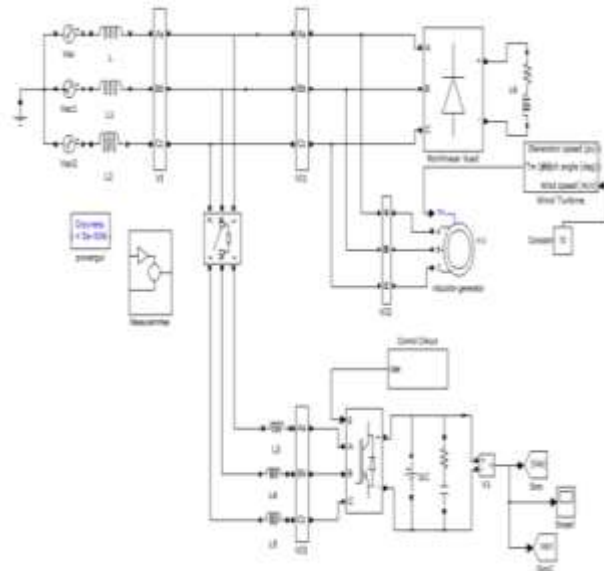

Fig.4: UPQC based wind non-linear load

This allows for an analysis of the system's performance with and without the UPQC by turning it on at the time of 0.3s. Table 1 lists the simulation parameters that were used. If you start out with an unreferenced UPQC current, it will start tracking your reference current after 0.06 seconds, as illustrated in Figure 3.13. This means that the excess power after feeding the non-linear load is supplied back to the source when UPQC is turned off, and it means the same thing when it's turned on.

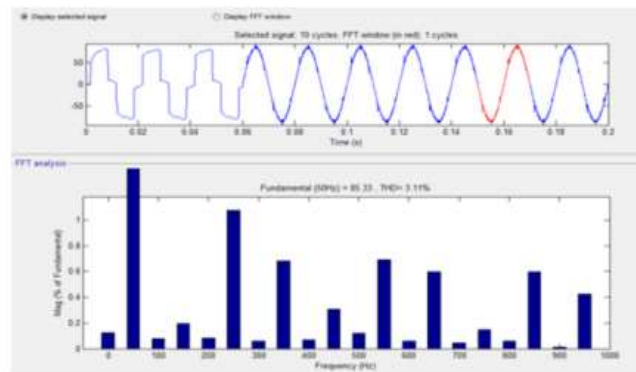

Fig. 5: FFT Analysis of Phase A Source Current using PQ theory of Current.

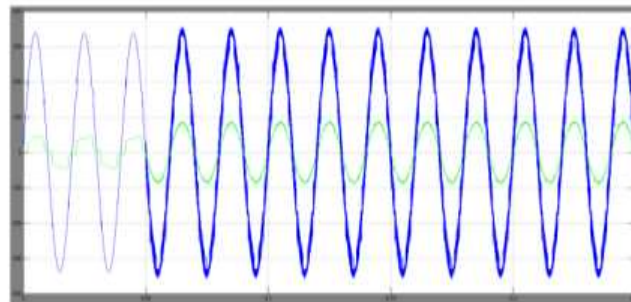

Fig. 6: Simulation results of source side voltage and current

D. CONCLUSION

The control techniques used in the proposed system include d-q theory and vector control technique. Uninterruptible Power Quality Control (UPQC) compensator, a versatile device that can operate in current control mode for compensating voltage variation, unbalance, and reactive power as well as a voltage stabiliser, is an effective way to mitigate PQ disturbances introduced to the grid. It may be used as a compensation for dips in the distribution network thanks to the latter capabilities. The simulation results show that the UPQC system's performance has been judged to be adequate for improving power quality at customers' homes. The UPQC control algorithm removes supply current harmonics and balances load in addition to restoring power factor to unity. The control algorithm of UPQC has the capacity to provide an independent DC bus. Within the IEEE constraints, the UPQC system decreased THD in nonlinear loads from 3.33 percent to 2.32 percent.

REFERENCES

- [1]. Q. Tande 'Applying Power Quality Characteristics of wind turbine for Assessing impact on Voltage Quality', Wind Energy, pp 52, 2002.
- [2] Z. Chen, E. Spooner, 'Grid Power Quality with Variable Speed Wind Turbines', IEEE Trans on Energy Conversion, Vol. 16, No .2, pp 148- 154, June 2001.
- [3] L. H. Hansen, L. Helle, F. Blaabjerg, E. Ritchie, S. Munk-Nielsen, H. Binder, P. S0rensen and B. Bak - Jensen "Conceptual Survey of Generators and Power Electronics for Wind Turbines ", Ris0 National Laboratory, Roskilde, Denmark, December 2001.
- [4] A. Arulampalam, M. Bames & N.Jenkins, Power quality and stability improvement of a wind farm using ST A TCOM, Proc. TEE Generation, Transmission & Distribution, Vol. 153, No.6, 2006, 701-710.
- [5] Z. Saad-Saoud, M.1.Lisboa, I.B. Ekanayake, N. Jenkins & G.Strbac, Application of ST A TCOMs to wind farms, Proc. TEE Generation, Transmission & Distribution, Vol.145, No. 5, 1998, 511-516.
- [6] A.Arulampalam, I.B.Ekanayake & N.Jenkins, Application study of a ST A TCOM with energy storage, Proc. IEE Generation, Transmission & Distribution, Vol. 150, No. 3, 2003, 373-384.
- [7] Fang Zheng Peng, Jih-Sheng Lai, 'Generalized Instantaneous Reactive Power Theory for Three-phase Power Systems', IEEE on instrumentation and measurement, vol. 45, no. I, Feb,1996.
- [8] Joao Afonso, Carlos Couto, Julio Martins, 'Active Filters with Control Based on the p-q Theory', IEEE industrial electronic society newsletter.vol. 47, n° 3, Sept. 2000, ISSN: 0746- 1240, pp. 5-10
- [9] Fang Zheng Peng, , George W. Ott, Jr., and Donald J. Adams,' Harmonic and Reactive Power Compensation Based on the Generalized Instantaneous Reactive Power Theory for Three-Phase Four-Wire Systems' IEEE Trans on power electronics, vol. 13, no. 6, nov 1998.
- [10] Leszek S. Czamecki:'Instantaneous Reactive Power p-q Theory and Power Properties of Three-Phase Systems' IEEE Trans on power delivery', vol. 21, no. I, Jan 2006.
- [11] K. Derradji Belloum, and A. Moussi, 'A Fixed Band Hysteresis Current Controller for Voltage Source AC Chopper' World Academy of Science, Engineering and Technology 45 2008.