

DTMF BASED CONTROLLED ROBOT VEHICLE

¹Sirigereddy Sasidhar,²Arekallu Nagamani,³K T Prashanthi,⁴Shaik Farzana

¹²³⁴Assistant Professor, Department Of EEE, Tadipatri Engineering College, Tadipatri, AP

ABSTRACT: In this paper, we can control the Robot using Dual Tone Multi Frequency (DTMF) technology. DTMF technology is most useful technique at present days. It is worked on to methods digital signal processing (DSP). Wireless-control of robots uses RF circuit that has the drawbacks of limited working range and limited control. This DTMF is gives advantage over the RF; it increases the range of working and also gives good results in case of motion and direction of robot using mobile phone through micro controller. This type of wireless communication gives the remote handling operation of Robot using DTMF.

Key words: DTMF, Atmega328P Controller, Mobile Robot.

I. INTRODUCTION

A robot is electro-mechanical machine which is guided by computer, Mobile phone or programming, and is thus able to do tasks on its own. The Robot Institute of America define “A robot is a reprogrammable multifunctional manipulator designed to move material parts, tools or specialized device through variable programmed motions for the performance of a variety of tasks.”

Conventionally, wireless controlled robots use RF circuits, which have drawbacks of limited working range & frequency range, use of mobile phones can overcome this limitation. It provides the advantages of robust control, working range as large as the coverage area of the service provider, no interference with other controllers and up to twelve controls[1].

DTMF Mobile ROBOT is a machine that can be controlled with a mobile. In this project, the robot is controlled by a mobile phone that makes a call to the mobile phone attached to the robot. In the course of a call, if any button is pressed, a tone corresponding to the button pressed is heard at the other end of the call. This tone is called "Dual Tone Multiple-Frequency" (DTMF) tone. The robot perceives this DTMF tone with the help of the phone stacked on the robot. The received tone is processed by the Arduino microcontroller with the help of DTMF decoder MT8870 IC the decoder decodes the DTMF tone is to its equivalent binary digit and this binary number is send to the microcontroller, the microcontroller is pre-programmed to take decision for any give input and output its decision to motor drivers in order to drive the motors for forward or backward motion or a turn.

II. BLOCK DIAGRAM OF PROPOSED SYSTEM

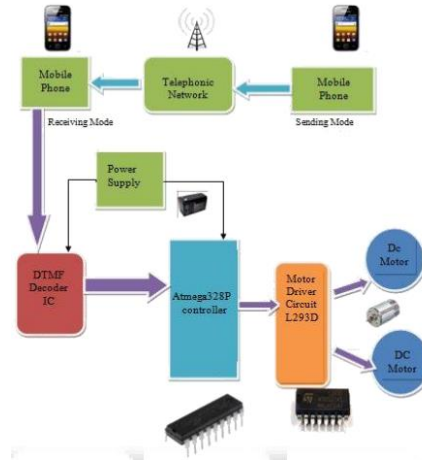

Fig. 1: Block Diagram of DTMF based Navigation Mobile Robot

III. HARDWARE DESCRIPTION

A. DTMF Decoder:

DTMF means Dual-Tone-Multi-Frequency. DTMF signaling is used for telecommunication signaling over analog telephone lines in the voice-frequency band between telephone handsets and other communication devices and the switching centre. The DTMF system generally uses eight different frequency signals transmitted in pairs to represent sixteen different numbers, symbols and letters. When someone presses any key in the key pad of the handset, a DTMF signal is generate unique tone which consists of two different frequencies one each of higher frequency range (>1KHz) and lower frequency (<1KHz) range. The resultant tone is convolution of two frequencies [2]. The frequencies and their corresponding frequency are shown in Table I.

	1209 Hz	1336 Hz	1477 Hz	1633 Hz
679 Hz	1	2	3	A
770 Hz	4	5	6	B
852 Hz	7	8	9	C
941 Hz	*	0	#	D

Table 1: DTMF Keypad Frequency

Each of these tones is composed of two pure sine waves of the low and high frequencies superimposed on each other. These two frequencies explicitly represent one of the digits on the telephone keypad. Thus generated signal can be expressed mathematically as follows:

$$f(t) = A_H \sin(2\pi f_H t) + A_L \sin(2\pi f_L t) \tag{1}$$

Where:

A_H, A_L : are the amplitudes
 f_H : high frequency range
 f_L : low frequency range

Each key has a specific Tone frequency. For example if the "5" key is pressed then generated frequency tone is $770 + 1336 = 2106$ Hz. The key "1" is pressed then frequency of $697 + 1209 = 1906$ Hz which is shown in below figure.

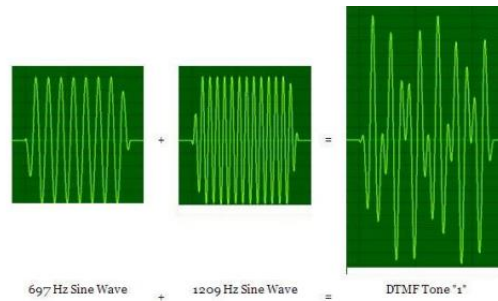

Fig. 2: Two Pure Sine Waves combine for form the DTMF Tone for "1"[3]

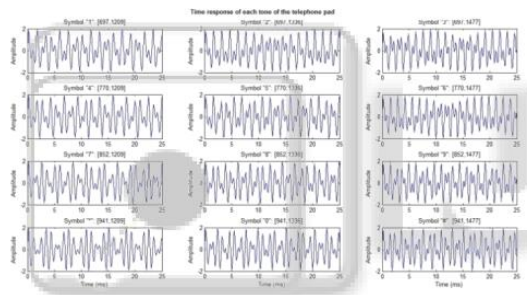

Fig. 3: DTMF Tone Frequency

1) CM8870 DTMF Decoder IC:

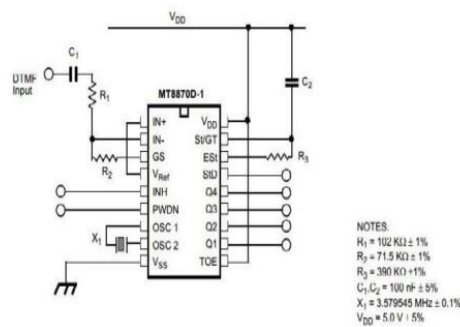

Fig. 4: MT-8870 DTMF Decoder Configuration [4]

The MT-8870 is a DTMF Receiver that integrates both band split filter and decoder functions into a single 18- pin DIP package. It is manufactured using CMOS process technology. The MT8870 offers low power consumption (35 mW max) and precise data handling. Its decoder uses digital counting techniques to detect and decode all 16 DTMF tone pairs into a 4-bit code.

The DTMF signal from the user mobile phone is picked up by the system mobile phone. The tip and ring of the microphone is connected to the specified pin of CM8870 as shown in the Fig. 4. C1, R1 and R2 have been adjusted for gain control of the input signal. Resistance R3 and capacitor C2 has been used to set the "guard time " which is a time duration through which a valid DTMF tone must be present for its recognition. The "Q-test " signal (pin15) indicates that the valid DTMF tone has been detected.

Increase the resistor between pin2 and pin3 (not the one connects to 100nF) from 100K to 220k, 330K or 470K. This increases the input gain from 1 to 2.2, 3.3 or 4.7 to suit your input signal strength [4].

B. Atmega328P Microcontroller:

ATmega328P [5] is a 32K 8-bit microcontroller based on AVR architecture. ATmega328P is commonly used in many projects and autonomous systems where a simple, lowpowered, low-cost micro-controller is needed. It has 14 digital input/output pins (out of which 6 can be exploited as PWM outputs), 6 analog input, 16 MHz crystal oscillator. The high-performance Atmel AVR RISC-based microcontroller combines 32KB ISP flash memory with read-while-write capabilities, 1KB EEPROM, 2KB SRAM, 23 general purpose I/O lines, 32 general purpose working registers, three flexible timer/counters with compare modes, internal and external interrupts, serial programmable USART, a byte-oriented 2-wire serial interface, SPI serial port, 6-channel 10-bit A/D converter (8-channels in TQFP and QFN/MLF packages), programmable watchdog timer with internal oscillator, and five software selectable power saving modes. The device operates between 1.8-5.5 volts.

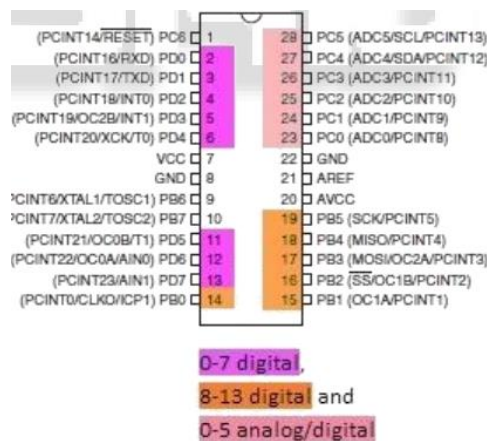

Fig. 5: Pin Diagram of Atmega328P

C. DC Motor Driver:

DC motor is electromechanical device that converts electrical energy into mechanical energy that can be used to do many works. It can produce mechanical movement to moving the wheels of the robot. DC motor has two wires, we can say them positive terminal and negative terminal, when these wires are connected

with power supply the shaft rotates. We can reverse the direction of the rotation. L293d chip is very safe to use for DC motor control. This L293D is 16bit chip. Chip is design to control four DC motor, there are two inputs and two outputs for each motor.

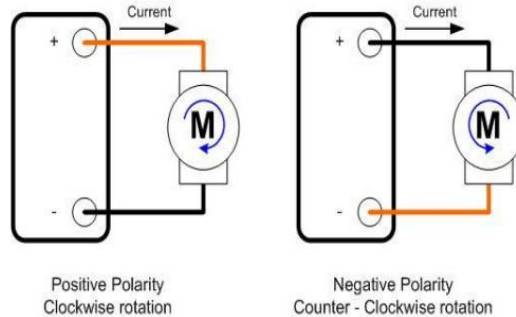

Fig. 6: Working of DC motor

There are two Enable pins on l293d. Pin 1 and pin 9, for being able to drive the motor, the pin 1 and 9 need to be high. For driving the motor with left H-bridge we need to enable pin 1 to high. And for right H-Bridge we need to make the pin 9 to high. If anyone of the either pin1 or pin9 goes low then the motor in the corresponding section will suspend working. It’s like a switch.

1) L293D Pin Diagram:

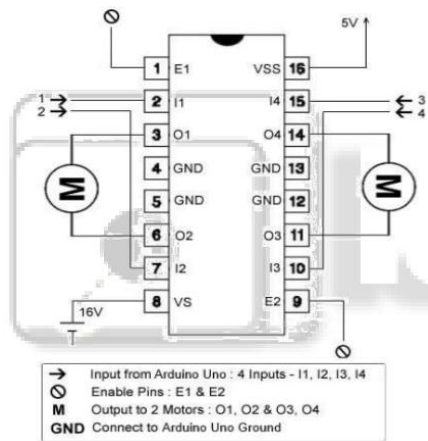

Fig. 7: L293D IC

2) Working of L293D:

The there 4 input pins for this L293D, pin 2,7 on the left and pin 15 ,10 on the right as shown on the pin diagram. Left input pins will regulate the rotation of motor connected across left side and right input for motor on the right hand side. The motors are rotated on the basis of the inputs provided across the input pins as LOGIC 0 or LOGIC 1. the motor.

3) L293D Logic Table:

Let's consider a Motor connected on left side output pins (pin 3,6). For rotating the motor in clockwise direction the input pins has to be provided with Logic 1 and Logic 0.

Pin 1 Enable	Pin 2	Pin 7	Function
HIGH	HIGH	LOW	Anticlockwise
HIGH	LOW	HIGH	Clockwise
HIGH	HIGH	HIGH	No Rotation
HIGH	LOW	LOW	No Rotation
LOW	X	X	No Rotation

Table 2: L293 Logic Table

Where X = HIGH/LOW

D. Working of Implemented System:

- Mobile phone which is connected to the robot is kept in auto receiving mode.
- For the control of robot, we have to make a call to the mobile phone which is attached to the robot using earphone. thus two mobile phone are connected via mobile network.
- When the call is received then press the button in your mobile.
- DTMF tone is received by the mobile that is connected with the robot through headphone.
- These signals are received by the DTMF decoder that decodes the signal in binary sequence to the microcontroller. Sequences are given in table 1
- Due to the programming in controller robot will move when pressing key in the mobile.
- Microcontroller outputs are in binary form. The high output of the controller drives the motor driver to drive the motor in forward direction.
- Similarly we can move the motor in backward, left, right motion and stop condition.
- According to the source code given here key 2 is for forward, key 4 is for left rotation, key 6 is for right rotation, key 8 for reverse rotation in this robot navigation.



Fig. 8: Functionality of used keypad in Mobile Phone [2]

E. Operation of the Circuit:

The DTMF signal from the user (Sender) mobile phone is picked up by the system (Receiver) mobile phone. Then the connection is established between the two phones, whatever phone key is pressed at the Sender

mobile phone, the corresponding DTMF tone is heard in the ear piece of the receiver phone. Received DTMF tone is fed to the DTMF decoder. The DTMF decoder will give the corresponding BCD value of the tone. This Output is connected to Q4, Q3, Q2, Q1 pin of MT8870 Decoder IC and this output is fed to ATmega328P Microcontroller pin 4,5,6,7 respectively. Based on the equivalent binary digit of the DTMF tone received by the Atmega328P Microcontroller, a decision is made for Pins 8,9,10 and 11 regarding which pins should be high or low. These pins are fed to the L293D IC as input. Based on the Controller decision, the Pins are either high or low which activates the motors and moves the vehicle.

F. DTMF tone Decoding Algorithm:

Low Frequency Group	High Frequency Group	Digit	O E	D 3	D 2	D 1	D 0
697	1209	1	H	0	0	0	1
697	1336	2	H	0	0	1	0
697	1477	3	H	0	0	1	1
770	1209	4	H	0	1	0	0
770	1336	5	H	0	1	0	1
770	1477	6	H	0	1	1	0
852	1209	7	H	0	1	1	1
852	1336	8	H	1	0	0	0
852	1477	9	H	1	0	0	1
941	1209	*	H	1	0	1	0
941	1336	0	H	1	0	1	1
941	1477	#	H	1	1	0	0

Table 3: DTMF Tone Decoding

IV. PROPOSED METHOD

The operational flowchart of the system is shown in Figure 9.

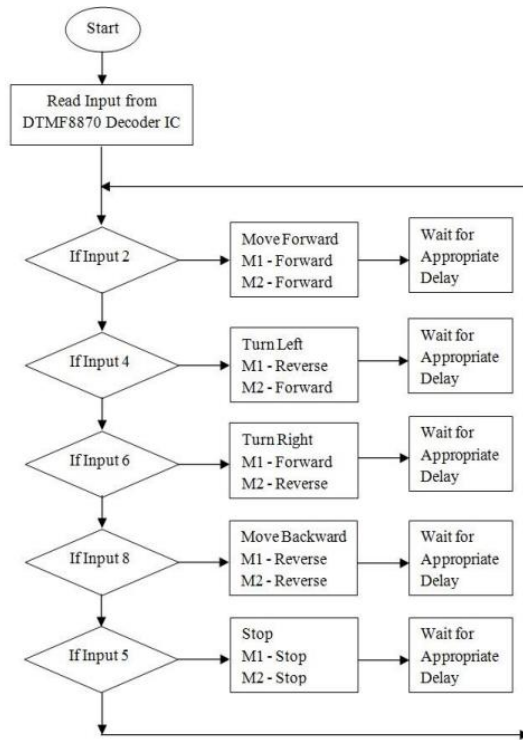

Fig. 9: Flow diagram of system

V. CIRCUIT SIMULATION

The Simulation of the circuit has been done on Proteus Professional v7.8 software package. The Simulation of the circuit is shown in figure 6. Atmega328P Microcontroller has been used in simulation. Four DC Motor are connected to Port B (Pin 2,3,4,5) of Microcontroller through H-Bridge driver Circuit.

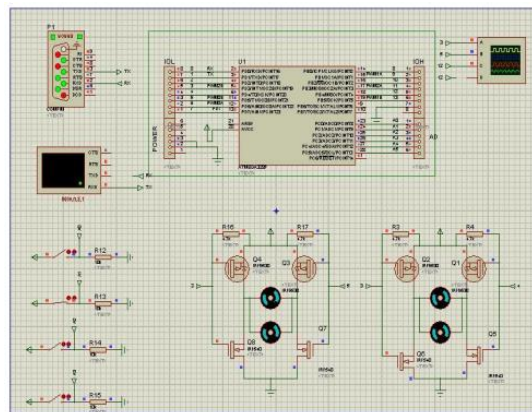

Fig. 10: Circuit Simulation in Proteus Simulator

VI. CIRCUIT DIAGRAM

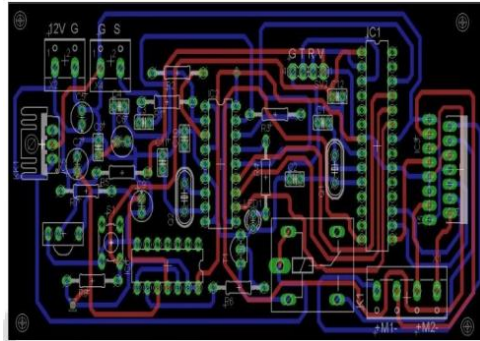

Fig. 11: Printed Circuit Board for DTMF based Controlled Robot

APPLICATION

- This type of wireless communication (GSM) gives the security of robots when the owner is not present.
- Operating robot from a remote place anywhere in the world with any telecommunication device having DTFM technology.

VII. RESULTS

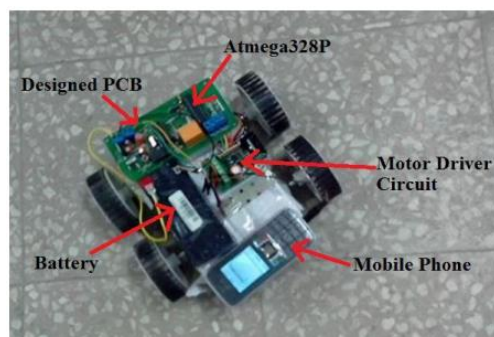

Fig. 12: Designed Robot



Fig. 13: Simulation Result when Press Key is '6'

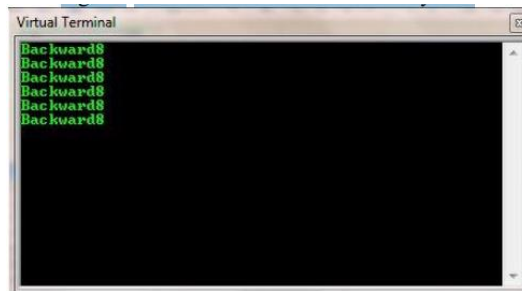

Fig. 14: Simulation Result when Press Key is '8'

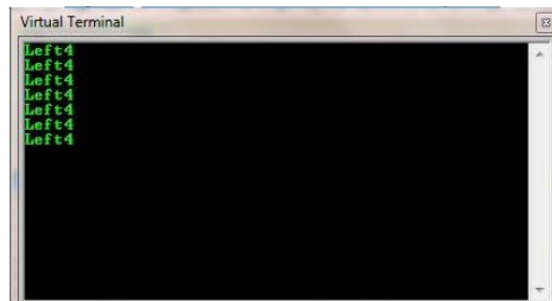

Fig. 15: Simulation Result when Press Key is '4'

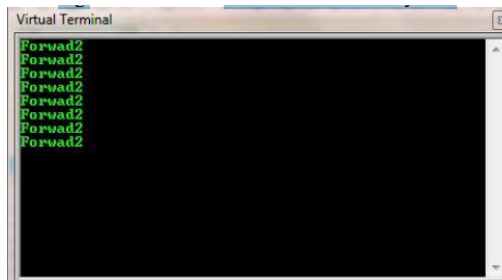

Fig. 16: Simulation Result when Press Key is '2'

VIII. CONCLUSION

By developing this robotic vehicle, we have overcome the drawbacks of RF communication which have a limited range whereas this car can be controlled from anywhere just using this DTMF technology. In these

project with the use of a mobile phone for robotic control can overcome these limitations. It provides the advantages of robust control, working range as large as the coverage area of the service provider, no interference with other controllers and up to twelve controls. Although the appearance and capabilities of robots vary vastly, all robots share the features of a mechanical, movable structure under some form of control.

REFERENCES

1. Awab Fakh, Jovita Serrao, "Cell Phone Operated Robotic Car." *International Journal of Scientific & Engineering Research*, ISSN 2229-5518.
2. Yun Chan Cho and Jae Wook Jeon "Remote Robot control System based on DTMF of Mobile Phone", *IEEE International Conference INDIN 2008*, July 2008.
3. <http://www.dialabc.com/sound/dtmf.html>
4. http://www.robotplatform.com/howto/L293/motor_driver_1.html
5. <http://www.atmel.in/devices/ATMEGA328.aspx>
6. Datasheet MT8870 Zarlink Semiconductor page 6.