

# INTELLIGENT OFFICE CHAIR USING RASPBERRY PI

<sup>1</sup>Lingampally Shivprasada,<sup>2</sup>I.Raghava Krishna,<sup>3</sup>K.Devendher,<sup>4</sup>B.Sandyarani

<sup>1,2,3,4</sup>Assistant Professor

Department Of ECE

Kshatriya College of Engineering

## ABSTRACT

In offices related to software, working professors in schools, colleges, etc, people sit for longer hours. Due to this they suffer with many health issues like overweight, joint pain, back pain, etc. this has become an increasing problem now a days.

To overcome this, the project is designed which is called as “Intelligent Office Chair”. This chair instructs the person sitting on the chair if he/she sit for long duration. Also this chair height can be adjusted up or down through the app.

To prove the concept practically, a proto type module is designed and developed using Raspberry pi, Using the IP address we can adjust the height, buzzer to remind the person that he/she is sitting more than the normal time so that they can take a break for some time duration. Ultrasonic sensor is also used to instruct the person, if he/she isn’t sitting properly.

The chair measures different parameters designed through sensors like ultrasonic sensor for distance measurement of the posture of the person, IR sensor for obstacle detection etc.

This project is designed with most demanding technology that is Raspberry pi. Preliminary results show that the Chair combined with case-study smart phone application can accurately detect the parameters and indicates or informs through the output equipment Vibrator etc.

In this project IP address plays a major role, with the help of that we built this project. With the help of Relay we can sense the Vibration

## I. INTRODUCTION

### 1.1 INTRODUCTION OF PROJECT:

Recently, various systems and applications utilizing IoT technology have been developed to help people in addressing issues that occur in our everyday life. Most people today spend more than half of the day on chairs for various purposes such as studying, driving, or working. For this reason, modern people are afflicted with waist disease such as lumbar disc, hip twisting and scoliosis, which rarely occurred in the past. For this reason, many hospitals which specialize in treating spines have been established nowadays.

In this project work, a Smart IoT Chair which supplements the limitations like sitting properly, taking breaks, drinking water, etc makes users sit correctly with recognition of their own current state by providing intuitive and visualized data in real time to Smartphone application. We can decrease back and hip pain caused by sitting for a long time through dispersing the pressure on the back and hip by dimidiating correcting posture of a person sitting on the chair. The focus is on ease of use, and allowing simple data connections with little programming required. The Smart IoT Chair implemented by this study can be used in various fields. First application area that we are targeting is in games for leisure or for posture calibration. With these games, the goal would be to correct user’s posture while enjoying games by directing appropriate sitting position opposite to the user’s usual habit based on collected data.

In addition, it can analyze sitting pattern of each individual and stimulus such as vibration or sound. Furthermore, other Smart devices can also be created by combining other furniture with this IoT

device. (e.g., a bed which analyzes sleeping pattern, a sofa or kitchen chair that provides custom services). As an immediate future work, we plan to precisely quantify the sensing ranges of our custom designed sensors, conduct thorough evaluation, deploy the chairs at a larger scale, and employ a gateway to collect posture data from large number of chairs make the project work more realistic, much importance is given for practical orientation, therefore a prototype module is constructed for the demonstration purpose. This module simulates the real working system and based on this technology with slight changes in the structure and motor ratings, the chair can be constructed for real applications. The chair is constructed with electronics, electrical & mechanical components.

### 1.2 BLOCK DIAGRAM:

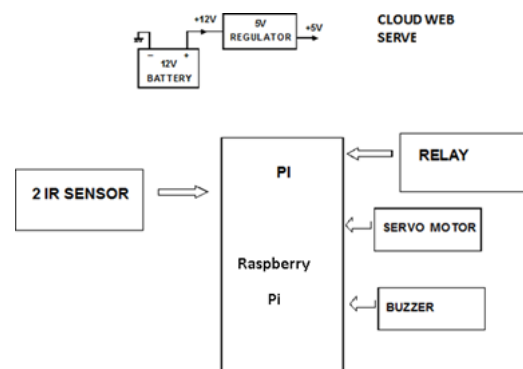

### 1.3 EXPLANATION OF EACH BLOCK:

#### 1.3.1 FUNCTIONAL

The functional description of the project work “Intelligent Office Chair” is

explained in this chapter. For better understanding, the total module is divided into various blocks and each block explanation is provided here. The diagrams (block diagram and circuit diagram) of this project work are provided in the next chapter. The following is the description of the over all function or operation of the project work.

#### 1.4 RASPBERRY PI:

##### Why Raspberry Pi Pico?



Fig 1. Raspberry Pi Pico

A Raspberry Pi Pico is a low-cost microcontroller device. Microcontrollers are tiny computers, but they tend to lack large volume storage and peripheral devices that you can plug in (for example, keyboards or monitors).

A Raspberry Pi Pico has GPIO pins, much like a Raspberry Pi computer, which means it can be used to control and receive input from a variety of electronic devices.

Raspberry Pi refers to a series of small single-board computers developed in the United Kingdom by the Raspberry Pi Foundation in association with Broadcom. The boards have been made keeping in mind the promotion of teaching basic computer science to kids. The latest offering by Raspberry Pi is the Raspberry

it is a microcontroller board built on silicon and designed at the Raspberry Pi Foundation.

#### 1.5 OBSTACLE SENSING CIRCUIT DESIGNED USING IR SENSORS

The main block in the project is the Obstacle Sensing circuit Designed with IR Sensors that are arranged on the chair to sense whether the person has sit or not. The obstacle-sensing block is designed with LM567 IC, this is a tone decoder IC, and also it generates tone frequency. For identifying the obstacles, a set of sensors are used with a 567 IC. The obstacle sensing block is designed with infrared sensors; a set of IR sensors are used as IR signal transmitting LED and IR signal receiving LED. These sensors are arranged side by side and are mounted on the walking stick. Both the sensors are wired with IC 567, this is a tone frequency generator cum decoder IC, means this IC can produce a tone frequency of up to 20 KHz, and the same IC also can decode the frequency. Since this IC can perform two different functions, the IR signal transmitting LED is connected at the output of tone signal generating part of IC, similarly the IR signal receiving LED is connected at the output of tone signal decoding part of IC. The tone signal

generating part is configured as free running oscillator, with the help of a resistor and capacitor connected externally to this oscillator frequency can be adjusted. When the circuit is energized it starts producing a continuous chain of square pulses. The output of this oscillator is amplified and fed to IR LED. This LED radiates the signal in to air and depending up on the signal strength or radiating power, the range can be increased. The IR signal delivered from the IR LED transmitted in a line like a laser beam, this beam is invisible and harmless. When the transmitted laser beam interrupted by any obstacle, this beam will be disturbed by the object and some of the signal will be reflected, this reflected signal will be received by the receiver infrared LED. The output of IR-Receiver is (proportional to reflected wave) found for matching (comparing) with that of transmitted wave, and then the output of the IC will becomes low automatically (If both are equal then output of this IC becomes low). The output of this tone decoder IC is fed to microcontroller.

The basic function of the detector circuit is by radiating energy into space through IR LED and detecting the echo signal reflected from an object. The reflected energy that is returned to the IR sensor indicates the presence of a object which



Fig .2: IR Sensor

An infrared sensor is an electronic instrument that is used to sense certain characteristics of its surroundings by either emitting and/or detecting infrared radiation. It is also capable of measuring heat of an object and detecting motion. Infrared waves are not visible to the human eye. In the electromagnetic spectrum, infrared radiation is the region having wavelengths longer than visible light wavelengths, but shorter than microwaves. The infrared region is approximately demarcated from 0.75 to 1000 $\mu$ m. IR (infrared) sensors detect infrared light. The IR light is transformed into an electric current, and this is detected by a voltage or amperage detector.

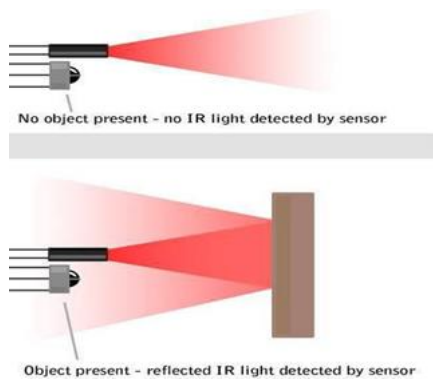

Fig .3: IR

**1.6 ULTRASONIC SENSOR:**

Ultrasonic sensors work on a principle similar to radar or sonar which evaluates attributes of a target by interpreting the echoes from radio or sound waves respectively. Ultrasonic sensors generate high frequency sound waves and evaluate the echo which is received back by the sensor. Sensors calculate the time interval between sending the signal and receiving the echo to determine the distance to an object. This technology can be used for measuring: wind speed and direction (anemometer), fullness of a tank and speed through air or water. Further applications include: humidifiers, sonar, medical ultra pornography, burglar alarms and non-destructive testing. Systems typically use a transducer which generates sound waves in the ultrasonic range, above 20,000 hertz, by turning electrical energy into sound, then upon receiving the echo turn the sound waves into electrical energy which can be measured and displayed.

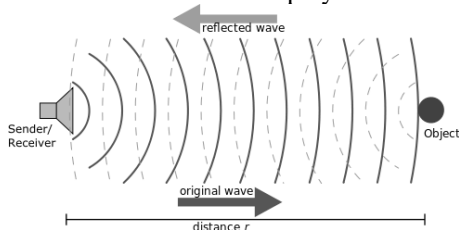

Fig .4: Ultrasonic Distance Measurement

**SERVOMOTOR:**

A servo motor is a type of motor that can rotate with great precision. Normally this type of motor consists of a control circuit that provides feedback on the current position of the motor shaft, this feedback allows the servo motors to rotate with great precision. If you want to rotate an object at some specific angles or distance, then you use a servo motor. It is just made up of a simple motor which runs through a servo mechanism. If motor is powered by a DC power supply then it is called DC servo motor, and if it is AC-powered motor then it is called AC servo motor. For this tutorial, we will be discussing only about the DC servo motor working. Apart from these major classifications, there are many other types of servo motors based on the type of gear arrangement and operating characteristics. A

servo motor usually comes with a gear arrangement that allows us to get a very high torque servo motor in small and lightweight packages. Due to these features, they are being used in many applications like toy car, RC helicopters and planes, Robotics, etc.

Servo motors are rated in kg/cm (kilogram per centimeter) most hobby servo motors are rated at 3kg/cm or 6kg/cm or 12kg/cm. This kg/cm tells you how much weight your servo motor can lift at a particular distance. For example: A 6kg/cm Servo motor should be able to lift 6kg if the load is suspended 1cm away from the motors shaft, the greater the distance the lesser the weight carrying capacity. The position of a servo motor is decided by electrical pulse and its circuitry is placed beside the motor.

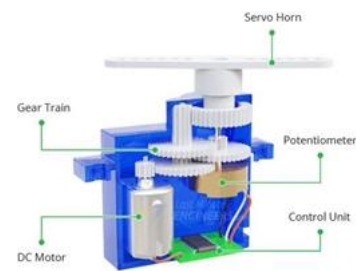

Fig .5: Servomotor

**BUZZER:**

The buzzer is a sounding device that can convert audio signals into sound signals. It is usually powered by DC voltage. It is widely used in alarms, computers, printers and other electronic products as sound devices. It is mainly divided into piezoelectric buzzer and electromagnetic buzzer, represented by the letter "H" or "HA" in the circuit. According to different designs and uses, the buzzer can emit various sounds such as music, siren, buzzer, alarm, and electric bell.



Fig .6 Buzzer

**II. LITERATURE SURVEY**

1.Ergonomic Design of Smart Office Chairs

- Goh, Y. M., & Nagayama, Y. (2019). Development of a Smart Office Chair with Ergonomic Features. Proceedings of the 20th Congress of the International Ergonomics Association.
- Al-Jumaily, A. A., & Lutteroth, C. (2019). Smart Chair for Ergonomic Workplace Monitoring and Intervention. 2019 IEEE

International Conference on Systems, Man and Cybernetics (SMC).

- Chen, C. Y., & Cheng, F. T. (2017). Ergonomics Design of Smart Office Chair based on Fuzzy System and RFID Technique. *Procedia Manufacturing*, 10, 790-797.

2. Health Monitoring and Well-being in Smart Office Chairs

- Chatzakis, E., Soudris, D., & Andrikopoulos, G. (2018). A Smart Chair for Posture Monitoring. 2018 IEEE International Conference on Industrial Technology (ICIT).
- Chalamala, B. R., & Waghmare, L. M. (2020). IoT Enabled Smart Office Chair for Health Monitoring. 2020 IEEE Region 10 Symposium (TENSymp).
- Hwang, W., & Woo, S. (2020). Development of a Smart Office Chair for Stress Reduction using EEG-based Biosignals and Seat Vibration. *International Journal of Precision Engineering and Manufacturing-Green Technology*, 7(5), 1139-1147.
- 3. Connectivity and Automation in Smart Office Chairs
- Goli-Malekabadi, Z., & Barreto, A. (2019). A Smart Office Chair for Energy Conservation in Buildings. 2019 IEEE International Symposium on Technology and Society (ISTAS).
- Ho, T. K., & Ng, C. H. (2018). A Smart Chair with Sensor Networks for Office Automation. 2018 15th IEEE Annual Consumer Communications & Networking Conference (CCNC).
- Sathyanarayanan, S., Sridhar, L., & Jain, S. (2020). Smart Office Chair with Gesture Recognition and IoT Integration. 2020 International Conference on Electronics and Sustainable.

III. CIRCUIT CONNECTIONS AND RESULTS

3.1 CIRCUIT DIAGRAM:

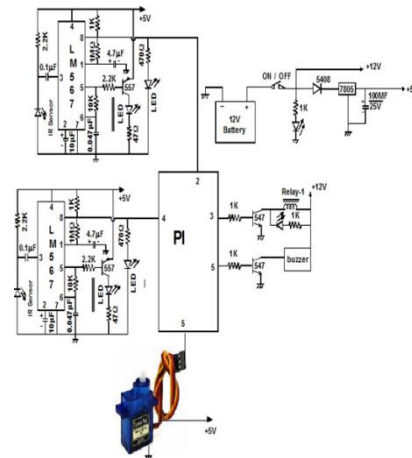

3.2 Result of Our Project:

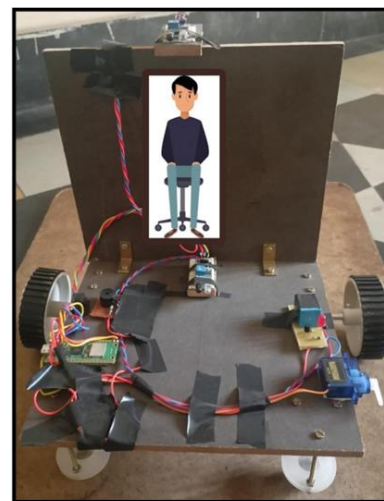
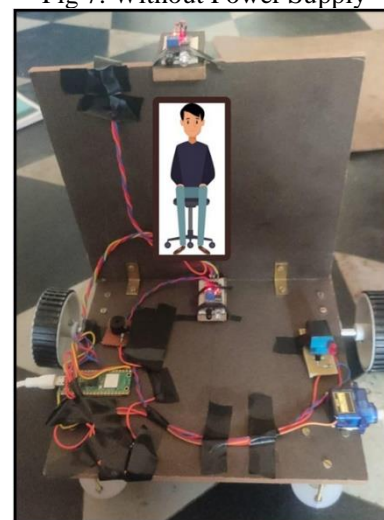

Fig 7. Without Power Supply



IV. CONCLUSION AND FUTURE SCOPE CONCLUSION:

The project work “Intelligent Office Chair” is designed and developed successfully. For the



demonstration purpose, a prototype module is constructed; and the results are found to be satisfactory. Since it is a prototype module, a simple module is constructed, which can be used for many remote applications.

While designing and developing this proto type module, we have consulted few experts, these professionals working at different organizations belongs to Hyderabad, helped us while building this module. Since it is a prototype module, much amount is not invested, the whole module is constructed with locally available components, and they are not up to the requirement. Some of the modifications must be carried out in design and is essential to make it as real working system. This project revealed that building a relatively low cost, high precision controlled chair and voice announcement.

The major and critical task is preparing the software for performing the tasks depending on the inputs. The performance of the machine purely depends on the software (code) we define in the Raspberry pi. The technology utilized here is for developing the prototype module only; it has to be enhanced to develop it into a real working system.

#### **FUTURE SCOPE:**

##### **1. Artificial Intelligence and Machine**

**Learning:** Smart office chairs could integrate advanced artificial intelligence (AI) and machine learning capabilities to better understand user behavior and preferences. AI algorithms could analyze data collected from sensors and provide personalized recommendations for optimal seating positions, posture corrections, and activity suggestions.

##### **2. Health and Well-being Features:**

Future smart office chairs may incorporate additional health and well-being features. For example, they could include biometric sensors to monitor vital signs such as heart rate, stress levels, or even provide alerts for prolonged inactivity. This would help users maintain a healthier and more active lifestyle while working.

##### **3. Advanced Connectivity and IoT**

**Integration:** Smart office chairs could further enhance connectivity and integration with other Internet of Things (IoT) devices and systems in the office environment. They could connect with smart lighting, climate control systems, or even virtual assistants, creating a more integrated and personalized work environment.

##### **4. Gamification and Virtual Reality:**

Future smart office chairs might incorporate elements of gamification and virtual reality (VR) to engage users and promote healthy sitting habits. They could use VR technology to simulate active environments or offer interactive exercises during breaks to encourage movement and combat sedentary behavior.

##### **5. Environmental and Sustainability Features:**

As sustainability becomes increasingly important, smart office chairs could incorporate eco-friendly materials and energy-efficient technologies. For example, they might use renewable energy sources for charging or incorporate recyclable components, reducing their environmental impact.

##### **6. Gesture and Voice Control:**

Future smart office chairs may implement gesture recognition and voice control features. Users could adjust chair settings, initiate specific actions, or interact with other connected devices simply by using hand gestures or voice commands, providing a more intuitive and hands-free experience.

##### **7. Augmented Reality (AR)**

**Integration:** Smart office chairs could integrate with augmented reality (AR) technologies to provide users with visual feedback and guidance on correct posture and ergonomics. AR overlays could assist users in making real-time adjustments to their sitting position, minimizing the risk of discomfort or injury.

##### **8. Enhanced Analytics and Insights:**

Smart office chairs may provide more advanced analytics and insights to users and organizations. They could generate detailed reports on sitting habits, productivity levels, and even suggest personalized recommendations for optimizing work habits and well-being. It's important to note that the future scope of smart office chairs is speculative, and actual developments may vary based on technological advancements, market demand,

and user preferences. However, these potential areas highlight the possibilities for smart office chairs to become more intelligent, interactive, and tailored to individual needs in the coming years.