

## MANHOLE MANAGEMENT SYSTEM

<sup>1</sup>M Sunitha, <sup>2</sup>K Amarender, <sup>3</sup>Dr Purushotham Nayak, <sup>4</sup>S Ayesha

<sup>1,2,3</sup>Assistant Professor, <sup>4</sup>Student

Department Of ECE

Christu Jyothi Institute Of Technology & Science, Colombo Nagar, Telangana

### ABSTRACT

A smart city is the future goal to have cleaner and better amenities for the society. Smart underground infrastructure is an important feature to be considered while implementing a smart city. Drainage system monitoring plays a vital role in keeping the city clean and healthy. Since manual monitoring is incompetent, this leads to slow handling of problems in drainage and consumes more time to solve. To mitigate all these issues, the system using a wireless sensor network, consisting of sensor nodes is designed.

The project aims in designing a manhole management system using IOT which alerts the managing station through web page when any manhole crosses its threshold values and also the system monitor the sensors data on LCD module. This system reduces the death risk of manual scavengers who clean the underground drainage and also benefits the public.

The project makes a use of water level sensor, water flow sensor, Temperature sensor, Gas sensor and raspberry pi zero w processor. The controlling device of the whole system is raspberry pi processor. In this rise in temperature, explosion due to toxic gases, overflow, manhole lid left open is detected by the sensors. The signals from the sensors are fed to the raspberry pi, which is programmed to generate alerts. In this we use sensors to detect blockage, floods, and gases. The sensors will identify the clogging inside the drainage system and will give information to the user through email and further actions will be taken care by the municipal.

Nowadays, accidents due to broken and missing manhole covers are quite frequent. Manholes are not monitored properly in developing countries. These accidents can lead to serious injuries and also death.

Hence, here we propose a system to overcome this problem. We have included an array of sensors for complete monitoring of the manhole cover so that such accidents can be prevented. This project includes a gas cover to monitor the gas emitted from the sewage systems so that toxicity can be monitored, the internal temperature is also monitored if a check for a change in the temperature as the property of manhole change with temperature which could need to crack formation, Also, a float sensor is used to indicate

when the water level goes beyond a certain level, in case of any alert due to any of the parameters we check on the IOT website. Also, all the parameters are continuously updated on the website.

### I. INTRODUCTION

#### 1.1 INTRODUCTION OF THE PROJECT:

For a clean and healthy environment, many Indian cities have an underground drainage system that is controlled by the Municipal Corporation. The water in the drainage system is occasionally mixed with pure water due to poo upkeep Infections and diseases can be spread through the drainage system. Because of climate change, drainage is affected throughout the year, and the environment is dynamic, people's daily lives are disrupted. To fix all drainage system concerns and to send notifications to the municipal corporation through web page informing them of the state of the drainage system so that officials can take the necessary steps to restore the drainage system. A gas sensor was used to detect the gas produced within the bio-waste drainage system, preventing it from escaping. The pressure inside the drainage system produced an explosion. The purpose of this design is to track the drainage system using the sensor. When the sewage system is obstructed, water overflows, or the drainage lid is removed, sensors monitor the drainage and send the data to a nearby municipal corporation official via integrated Wi-Fi, where the water overflow and gas value are presented live in the cloud for later examination. The sewage system exhibits instability and uncertainty due to multivariable, nonlinear, temporal variation, and random treatment processes. This model's purpose is to create a low cost, customizable solution for detecting obstructions and stinky or foul-smelling gases. Sensors detect the water level, and if the difference between the two levels exceeds the threshold value, Raspberry pi pico w is connected to the sensors' output. It looks at the previously set threshold level which is tracked via IoT. Thing speak, an IoT server analytics solution, gas detection on the monitor. The most significant benefit of this technology is that it can save sewage workers from dying from harmful gas exposure.

For a clean and healthy environment, many Indian cities have an underground drainage system that is controlled by the Municipal Corporation. The water in the drainage system is occasionally mixed with pure water due to poor upkeep. Infections and diseases can be spread through the drainage system. Because of climate change, drainage is affected throughout the year, and the environment is dynamic, people's daily lives are disrupted. To fix all drainage system concerns and to send notifications to the municipal corporation informing them of the state of the drainage system so that officials can take the necessary steps to restore the drainage system. A gas sensor was used to detect the gas produced within the bio-waste drainage system, preventing it from escaping. The pressure inside the drainage system produced an explosion. The purpose of this design is to track the drainage system using the sensor. When the sewage system is obstructed, water overflows, or the drainage lid is removed, sensors monitor the drainage and send the data to a nearby municipal corporation official via integrated Wi-Fi, where the water overflow and gas value are presented live in the cloud for later examination. The sewage system exhibits instability and uncertainty due to multivariable, nonlinear, temporal variation, and random treatment processes. This model's purpose is to create a lowcost, customizable solution for detecting obstructions and stinky or foul-smelling gases. Two ultrasonic sensors detect the water level, and if the difference between the two levels exceeds the threshold value, an alert message is delivered to the web server.

**1.2 BLOCK REPRESENTATION:**

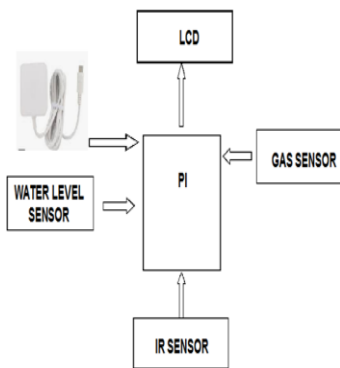

**Figure 1: BLOCK DIAGRAM**

**1.3 WATER LEVEL SENSOR:**

The water level sensor is used to determine how much water is in the manhole. If the water has increased from its original level, a notification will be sent to the authorities.

Water level sensor can be used with a microcontroller to actuate a pump, an indicator, an alarm, or another device. Can use them with hydroponics, saltwater tank, freshwater tank, gardening, aquariums for power head control, pet bowls, fish tanks, filtration, heating, pumps, ponds, basement alarms, boats, air condition drain pans, pressure washers, carpet cleaning machine, reef aquarium, fluid control, ice machines, coffee pots, marine, automotive, automobiles, tropical fish tanks, evaporator coils, etc. The best thing about this water level sensor is this is compact and lightweight. Though you can't measure a large water depth i.e., 4 cm maximum, but the reading will be linear, i.e., the output to analog signal is directly proportional to the water level.

Water level sensor in India and worldwide is popularly used for DIY student projects. As the output voltage is linear, it finds some applications in the industries.

**1.4 GAS SENSOR:**

Gas sensor is used widely in various applications to sense whether the gas is present or not, so that gas sensor is used to check whether the harmful gas presence in the manhole. If it detects any harmful gas, the message will be sent to the corporation office. The MQ-6 sensor is a sensitive component and it is adjustable on the board and also it is a protection resistor. LPG, isobutene, and propane are particularly sensitive to the MQ-6 gas sensor, whereas alcohol is less sensitive.

A gas sensor is a device which detects the presence or concentration of gases in the atmosphere. Based on the concentration of the gas the sensor produces a corresponding potential difference by changing the resistance of the material inside the sensor, which can be measured as output voltage. Based on this voltage value the type and concentration of the gas can be estimated.

The type of gas the sensor could detect depends on the sensing material present inside the sensor. Normally these sensors are available as modules with comparators as shown above. These comparators can be set for a particular threshold value of gas concentration. When the concentration of the gas exceeds this threshold, the digital pin goes high. The analog pin can be used to measure the concentration of the gas.

These sensors are normally available as modules (shown right), these modules consist of the gas sensor and a comparator IC. Now let's see the pin description of the gas sensor module which we will generally use with an Arduino. The gas sensor module basically consists of 4 terminals

**Vcc** – Power supply

**GND** –Power

supply

**Digital output** – This pin gives an output either in logical high or logical low (0 or 1) that means it displays the presence of any toxic or combustible gases near the sensor.

**Analog output** – This pin gives an output continuous in voltage which varies based on the concentration of gas that is applied to the gas sensor.

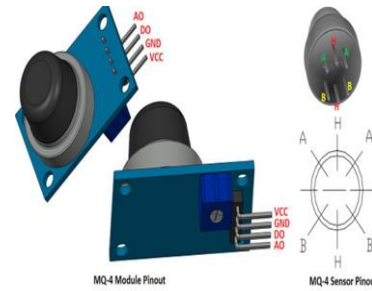

**Figure 2 GAS SENSOR**

A basic gas sensor has 6 terminals in which 4 terminals (A, A, B, B) acts input or output and the remaining 2 terminals (H, H) are for heating the coil. Of these 4 terminals, 2 terminals from each side can be used as either input or output (these terminals are reversible as shown in the circuit diagram) and vice versa.

The ability of a Gas sensor to detect gases depends on the chemiresistor to conduct current. The most commonly used chemiresistor is Tin Dioxide (SnO<sub>2</sub>) which is an n-type semiconductor that has free electrons (also called as donor). Normally the atmosphere will contain more oxygen than combustible gases. The oxygen particles attract the free electrons present in SnO<sub>2</sub> which pushes them to the surface of the SnO<sub>2</sub>. As there are no free electrons available output current will be zero. The below gif shown the oxygen molecules (blue colour) attracting the free electrons (black colour) inside the SnO<sub>2</sub> and preventing it from having free electrons to conduct current.

When the sensor is placed in the toxic or combustible gases environment, this reducing gas (orange colour) reacts with the adsorbed oxygen particles and breaks the chemical bond between oxygen and free electrons thus releasing the free electrons. As the free electrons are back to its initial position they can now conduct current, this conduction will be proportional the number of free electrons available in SnO<sub>2</sub>, if the gas is highly toxic more free electrons will be available.



**Figure3.SENSOR PINOUT**

## I. LITERATURE SURVEY

### 2.1 LITERATURE REVIEW:

The design space of wireless sensor networks, Wireless Communications Author:

Romer, K. Mattern Description: In the recent past, wireless sensor networks have found their way into a wide variety of applications and systems with vastly varying requirements and characteristics.

As a consequence, it is becoming increasingly difficult to discuss typical requirements regarding hardware issues and software support. This is particularly problematic in a multidisciplinary research area such as wireless sensor networks, where close collaboration between users, application domain experts, hardware designers, and software developers is needed to implement efficient systems. In this paper we discuss the consequences of this fact with regard to the design space of wireless sensor networks by considering its various dimensions. We justify our view by demonstrating that specific existing applications occupy different points in the design space.

Towards the Implementation of IoT for Environmental Condition Monitoring in Homes Author: Kelly S.D.T, Suryadevara, N.K, Mukhopadhyay S.C Description: In this paper, we have reported an effective implementation for Internet of Things used for monitoring regular domestic conditions by means of low cost ubiquitous sensing system. The description about the integrated network architecture and the interconnecting mechanisms for reliable measurement of parameters by smart sensors and transmission of data via internet is being presented. The longitudinal learning system was able to provide self-control mechanism for better operations of the devices in monitoring stage. The framework of the monitoring system is based on combination of pervasive distributed sensing units, information system for data aggregation, reasoning and context awareness. Results are encouraging as the reliability of sensing information transmission through the proposed integrated network architecture is 97%. The prototype was tested to generate real-time graphical information rather than a test bed scene

## I. CIRCUIT DESCRIPTION AND RESULT

### 5.1 CIRCUIT DIAGRAM:

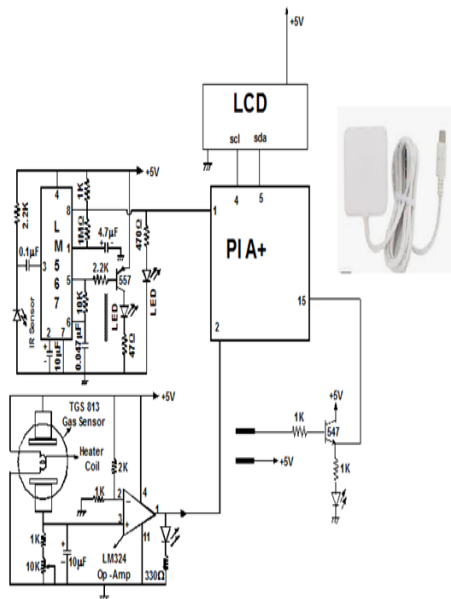

Fig 6: Circuit Diagram

### 5.2 RESULT:

Within the manhole and convert those inputs into electric output, this electric output acquired as a enter to Raspberry pi pico w embedded with Wifi modules and programmed in this sort of manner that each one the records is ship to server in precise time periods then the internet site presentations all stay readings of each node and the alert records into readable textual content .Offline textual content are also are dispatched to the given predefined LCD.

### 5.3 RESULT WINDOW:

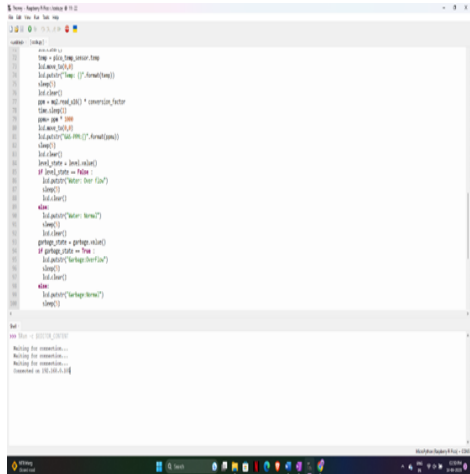

Fig 7 Result window stage I



The above picture represents the stage I result of the project. In this stage, the parameters- Gas,

temperature, water level and garbage level are displayed on the LCD.



Fig 8 Result Window stage II

The above picture represents the stage II result of the project. In this stage, the connection for communication between the person and the server is established, The values of the parameters are displayed on the web server page

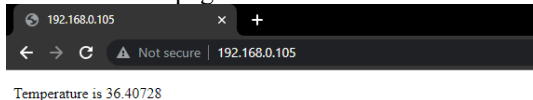

Fig 9 values displayed on web server



Fig 10 values displayed on LCD

### 5.4 WITH POWER SUPPLY:

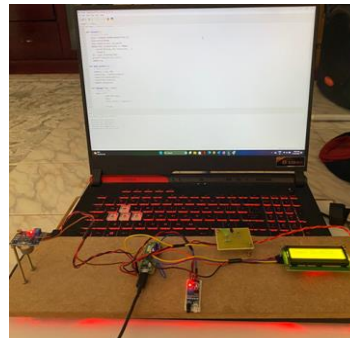
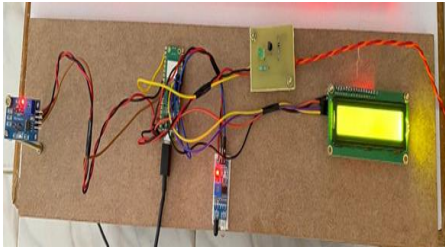

Fig 11. Upload window and Project Kit with power supply



**Fig 12: Project Kit with power supply**

## VI. APPLICATIONS & ADVANTAGES

### 6.1 APPLICATIONS:

- The system governing the flow of sewage from the pipes.
- Use of flow sensors to detect the variations in the flow.
- Get the prior alerts of blockages and locate them.
- Overflow of garbage will be detected prior.
- Overflow of water will be detected.
- Harmful gases will be detected if any in sewage.

### 6.2 Advantages:

Today's drainage system is not high-tech. So whenever there is blockage, it is difficult to figure out the exact location of the blockage. Also, early alerts of the blockage are not received. Hence detection and repairing of the blockage become time consuming. It becomes very inconvenient to handle the situation when pipes are blocked completely. Due to such failure of drainage line people face a lot of problems. So, this system proposes:

- Increment in safety precautions for manual cleaning.
- Real time monitoring and analysis of whole drainage system
- Detecting the pollutants, we can determine the level of risk in deploying the workers in particular manhole.
- Battery monitoring for easy maintenance
- Easy interpretable GUI for every type of users
- Automation and alerting in case for emergency and potential hazardous situation.

### 6.3 Disadvantages:

- The Raspberry Pi requires a significant amount of power to operate, which can be a challenge when used in a sewage.
- Only one parameter can be shown in the web page.
- Memory is limited.
- We must check the alerts manually.

## VII. CONCLUSION AND FUTURE SCOPE

### 7.1 CONCLUSION:

Underground monitoring is challenging problem. This project proposes different methods for monitoring and managing underground drainage system. It explains various applications like underground drainage and manhole identification in real time. Various parameters like temperature, toxic gases, flow and level of water are being monitored and updated on the internet using the Internet of Things. This enables the person in-charge to take the necessary actions regarding the same. In this way the unnecessary trips on the manholes are saved and can only be conducted as and when required. Also, real time update on the internet helps in maintaining the regularity in drainage check thus avoid the hazards. This paper addresses all about smart and real-time Drainage monitoring system through IOT applications for metropolitan cities. By using various sensors such as gas detection, water level as well as blockage detection we can monitor the real time scenario of drainage system by for detecting the problems in drainage system. By doing this we can be able to take particular action on the problems as we will receive the early alerts of blockage as well as increase. This paper can be used to design the smart and real time drainage system for monitoring as well as troubleshooting purpose.

### 7.2 FUTURE SCOPE:

In the destiny after securing underground drainages from dangerous gases and different contaminants. We can visit paintings on some other difficulty this is sewage water overflows wherein divert wastages from the busiest sewage line to others which can be able to flowing that more sewage waste. In the destiny, our concept may be focusing on the intake of water that's different most important difficulty otherwise automating entire sewage cleansing device with assist of robotics and tracking wastes earlier than dumping it into sea whether or not it's far dangerous to marine flowers and fauna, If a person pass towards dumping regulations we are able to song them and penalty may be despatched with minimum guide assist

### 7.3 REFERENCES :

1. <https://create.raspberrypi.cc/projecthub/sarful/raspberrypi-workshop->
2. <https://www.PI.cc/education/science-journal>
3. <https://www.pico W.cc/en/Guide/Introduction>
4. <https://www.hackerearth.com>
5. <https://www.raspberrypi.com/documentation/microcontrollers/raspberrypi-pico.html>
6. <https://thonny.org/>
7. <https://thonny.en.softonic.com/>
8. <https://mintbook.com/blog/digital-library>

[software-list/](#)

9. Muragesh S. K1 and Santhosha Rao  
"AutomatedInternet of Things for Underground Drainage and Manhole
10. Monitoring System for Metropolitan Cities"November2014
11. Prof. S A.Shaikh 1, Suvarna A. Sonawane.  
"Implementing Smart City Concept with Various Application Using IOT Based Technique"June 2017
12. Yash Narale,Apurva Jogal,Himani Chowdhary,S.P Bhosale "Underground Drainage Monitoring System Using IOT".International Journal of Advance Research Ideas And Innovations In Technology, Volume 4 Issue 1, January 2018
13. G. Gowthaman, K. Hari Haran "Automated Internet of Things for Underground Drainage and Manhole Monitoring System for Metropolitan Cities"ISSN 0974- 2239 Volume 4, Number 12 (2014), pp. 1211-1220
14. Retno Tri Wahyuni1\* Yusmar Palapa Wijaya2 Dini Nurmalasari "Design of Wireless Sensor Network for Drainage
15. Wirawam, S., Pratoma, I., and Mita, Nagahisa. "Design of Low Cost Wireless Sensor Network-Based Environmental Monitoring System for Developing Country".Proceedings of APCC2008