

AUTO TURN OFF FOR WATER PUMP WITH FOUR DIFFERENT TIME SLOTS FOR POWER SAVING APPLICATIONS

¹P.Prabhakar,²T.Supraja,³E.Renuka,⁴M.Ujwala

^{1,2,3}Assistant Professor,⁴Student

Department Of EEE

Christu Jyothi Institute Of Technology &Science,Colombo Nagar,Telangana

Abstract - Nowadays the modern technologies are helpful in all aspects of our life. Due to this lots of development done in the field of agricultural. The solar energy converted into electrical energy by photo voltaic cells. This energy stored in batteries during the day time to run the water pump for agriculture and distribute the water to the farm. The project is designed to operate the water pump at four different time slots. It prevents the difficulties of switching the pump on/ off manually. Real time clock interfaced to Arduino then Arduino give command to the corresponding relay to start the load and another command to switch off the load is programmed by the user. A matrix keypad helps to entering different time slots. Switching the pump ON/OFF manually these difficulties can be overcome using this project. There be an inbuilt real time clock (RTC)which keeps tracking the time and thus switches ON/OFF the pump accordingly.In this project, solar panel used to charge the battery a lcd display is interfaced to the to display time. We are setting the time slots from app through wifi communication.

Keywords: solar panel, Matrix keypad, RTC, LCD, Arduino,wifi

1.INTRODUCTION

Agriculture is an important part of Indian economy. The rapid growth in agriculture has helped Indian agriculture mark its presence at global level. India is one among top countries in terms of production of various agricultural commodities like paddy, wheat, vegetables, fruits etc. In India more than 60% of the population earns their livelihood from agriculture. As we approach a new millennium, there are growing concerns and repetitive warnings of water scarcity. With increasing demand for food and competing use within irrigation professionals to manage water effectively. Irrigation plays a master role in the following scenarios like: reduced rainfall, uneven distribution of rain fall, development of

agriculture in desert area etc. Irrigation has some of the advantages like: increase food production, optimum benefits of domestic water supply etc. Meanwhile some of the drawbacks of irrigation include: water-logging, dampness in weather, loss of valuable lands etc. In order to overcome the drawbacks of irrigation user can make use of the automatic solar water pump. In solar water pump control a farmer can reduce his manual efforts. Solar powered water pumps can deliver drinking water as well as water for livestock or irrigation purposes. Solar photovoltaicity is been widely used in different applications. Despite of various limitations of several energy sources, one of the most appropriate and simplest uses of photovoltaicity is water pumping [1]. Solar water pumps may be useful in small scale or community based irrigation. As large scale irrigation requires large volumes of water that in turn require a large solar panel and batteries for storage purpose.

A solar power pumping system are being used for developing country instead of other forms of energy because they are extremely durable and can also economic benefits. Solar powered water pumping systems can be the most appropriate solution, where the levels of solar radiation are extremely high. Solar powered water pumping systems provide basic needs of public like provide drinking water and water for agriculture etc. without the need for any kind of fuel or maintenance. A large scale SPPS can serve well over 240 people at a time . solar powered pumping system produce sufficient electricity directly from solar radiations to power livestock.Solar water pumps mainly used for small scale or community based agriculture fields as large scale requires large volumes of water. Which requires a solar pv array extremely large in size. It is not necessary to provide large PV array when water may be required only during some parts of the year. Thus making the system in efficient Solar PV water

pumping systems are mainly used for irrigation and drinking water purposes in India. Larger SPSS can deliver around 140,000lts of water/day from a total head of 10 meters. We are setting the time slots from app through wifi communication.

II.LITERATURE SURVEY

This section deals with the summary of alternate solutions to the problems existing with the present irrigation system. The solutions are as follows: Paper 1- PV system is the best solution for remote agriculture and for need such as water pumping for crops[1]. Zigbee technology that uses wireless transmission can enhance the security of the PV system. Zigbee technology is a wireless communication technology to connect local wireless nodes [1].It can be fixed in ambient environment which can be monitored in control room. The components used to build this system are solar panel, sensor, inverter, solar pumping motor, zigbee module[1]. Paper 2- Photovoltaic water pumping system involves the technique in which the energy produced by the panel is fed to the motor through a converter with two power stages: a DC/DC stage to boost the voltage of the panels and a DC/AC three-phase inverter to convert the DC voltage to three phase AC voltage set[2]. The three phase induction motor has a high degree of robustness, low cost, higher efficiency and lower maintenance cost compared to other types of motors and hence it is used. It uses a single PV panel which is used to drive low powered water pumps. Paper 3 - Another alternative is vector control of induction motor coupled with a centrifugal hydraulic pump, powered by a photovoltaic array. As shown in fig.2.1 the centrifugal pump is driven by an induction motor and fed by a voltage source inverter[3].It uses an induction motor which has lower maintenance compared to dc motor. The idea proposed in this paper is cost effective and is easy to use compared to the other alternate solutions discussed above because of use of dc motor. This idea can be of easy use to the farmers . Although zigbee is an advanced technology it is difficult for the user to implement and maintain it efficiently.

[1] A review of current status of solar photovoltaic water pumping system technology research and applications is presented. The study focuses on update on solar water pumping

technology, economic evaluation, environmental aspects and recent advances in materials and efficiency improvement of photovoltaic technology and experience of using solar PV pumps worldwide. Agricultural techniques are changing speedily because of current advancement in renewable energy technology. The current advancements in renewable energy can be successfully applied in the agriculture sector to minimize dependency on conventional crops irrigation techniques. Fields and crops irrigation are usually performed by water pumps (runs on fossil fuels) which can lead to environmental damage and high agricultural costs. The humidity sensors and global system for mobile (GSM) module are installed for automation and wireless control of irrigation to reduce manpower needs. [2] The paper has discussed about the possibility of implementing a solar based smart irrigation system which has been tested in lab and is to be taken to a village in Coimbatore, India. A system with a solar panel, moisture sensor, Arduino Microcontroller Unit and battery is implemented and tested in the lab. The power requirements for the area of the irrigation field we are covering is calculated and accordingly number of solar panels, battery, microcontroller units, wireless interface modules and moisture sensors are decided. Because of the variable atmospheric situation these conditions sometimes may vary from place to place in the huge farmhouse that makes very difficult to maintain the uniformity at whole places in the farmhouse manually. It is observed that for the first time an android phone-control the Irrigation system, which could give the facilities of maintaining uniform environmental conditions are proposed. [3] In this proposed system we utilize the solar energy from solar panels to pump water from bore well directly into a ground level storage tank based on the intensity of sun rays. The water is pumped into a ground level tank from which a simple valve mechanism govern the flow of water into the ground.

III. DESIGN OF HARDWARE

This chapter briefly explains about the Hardware implementation of auto on off the water pump in different timings using RTC . It discuss the circuit diagram of each module in detail.

3.1.ARDUINO UNO

The Arduino Uno is a microcontroller board based on the ATmega328 (datasheet). It has 14 digital input/output pins (of which 6 can be used as PWM outputs), 6 analog inputs, a 16 MHz ceramic resonator, a USB connection, a power jack, an ICSP header, and a reset button. It contains everything needed to support the microcontroller; simply connect it to a computer with a USB cable or power it with a AC-to-DC adapter or battery to get started.

The Uno differs from all preceding boards in that it does not use the FTDI USB-to-serial driver chip. Instead, it features the Atmega16U2 (Atmega8U2 up to version R2) programmed as a USB-to-serial converter. Uno board has a resistor pulling the 8U2 HWB line to ground, making it easier to put into DFU mode. Arduino board has the following new features:

- 1.0 pinout: added SDA and SCL pins that are near to the AREF pin and two other new pins placed near to the RESET pin, the IOREF that allow the shields to adapt to the voltage provided from the board. In future, shields will be compatible both with the board that use the AVR, which operate with 5V and with the Arduino Due that operate with 3.3V. The second one is a not connected pin, that is reserved for future purposes.
- Stronger RESET circuit.
- Atmega 16U2 replace the 8U2.

"Uno" means one in Italian and is named to mark the upcoming release of Arduino 1.0. The Uno and version 1.0 will be the reference versions of Arduino, moving forward. The Uno is the latest in a series of USB Arduino boards, and the reference model for the Arduino platform; for a comparison with previous versions, see the index of Arduino boards.



Fig: ARDUINO UNO

3.2. POWER SUPPLY

The power supplies are designed to convert high voltage AC mains electricity to a suitable low voltage supply for electronic circuits and other

devices. A power supply can be broken down into a series of blocks, each of which performs a particular function. A d.c power supply which maintains the output voltage constant irrespective of a.c mains fluctuations or load variations is known as "Regulated D.C Power Supply".

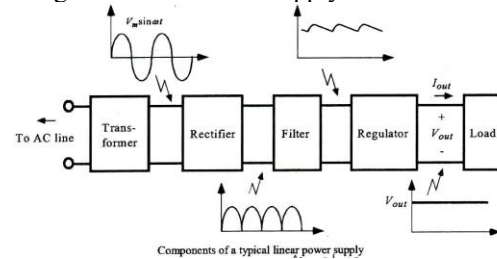

Fig:Power Supply

3.3 LCD

Liquid Crystal Display also called as LCD is very helpful in providing user interface as well as for debugging purpose. The most commonly used Character based LCDs are based on Hitachi's HD44780 controller or other which are compatible with HD44580. The most commonly used LCDs found in the market today are 1 Line, 2 Line or 4 Line LCDs which have only 1 controller and support at most of 80 characters, whereas LCDs supporting more than 80 characters make use of 2 HD44780 controllers



3.4 RELAYS

We know that most of the high end industrial application devices have relays for their effective working. Relays are simple switches which are operated both electrically and mechanically. Relays consist of an electromagnet and also a set of contacts. The switching mechanism is carried out with the help of the electromagnet. There are also other operating principles for its working. But they differ according to their applications. Most of the devices have the application of relays.

The main operation of a relay comes in places where only a low-power signal can be used to control a circuit. It is also used in places where only one signal can be used to control a lot of circuits. The

application of relays started during the invention of telephones. They played an important role in switching calls in telephone exchanges. They were also used in long distance telegraphy. They were used to switch the signal coming from one source to another destination.

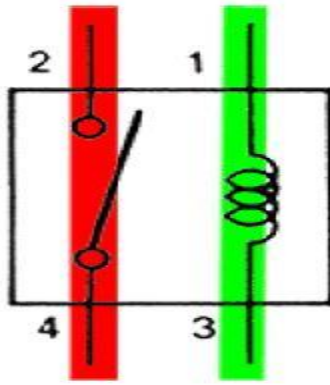

Fig: relay

3.5 PHOTOVOLTAIC

A PV cell is a simple p-n junction diode that converts the irradiation into electricity. Fig.3.2 illustrates a simple equivalent circuit diagram of a PV cell. This model consists of a current source which represents the generated current from PV cell, a diode in parallel with the current source, a shunt resistance, and a series resistance.

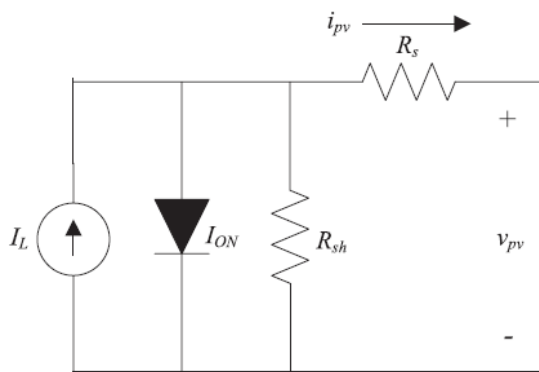

Fig. Equivalent circuit diagram of the PV cell

3.6 RTC

A **real-time clock (RTC)** is an electronic device (most often in the form of an integrated circuit) that measures the passage of time.

Although the term often refers to the devices in personal computers, servers and embedded

systems, RTCs are present in almost any electronic device which needs to keep accurate time of day.

The term *real-time clock* is used to avoid confusion with ordinary hardware clocks which are only signals that govern digital electronics, and do not count time in human units. RTC should not be confused with real-time computing, which shares its three-letter acronym but does not directly relate to time of day.

Purpose

Although keeping time can be done without an RTC,^[1] using one has benefits:

- Low power consumption^[2] (important when running from alternate power)
- Frees the main system for time-critical tasks
- Sometimes more accurate than other methods

3.7 ESP8266 WIFI

The **ESP8266** is a low-cost Wi-Fi microchip with full TCP/IP stack and microcontroller capability produced by Shanghai-based Chinese manufacturer, Espressif Systems.^[1]

The chip first came to the attention of western makers in August 2014 with the **ESP-01** module, made by a third-party manufacturer, Ai-Thinker. This small module allows microcontrollers to connect to a Wi-Fi network and make simple TCP/IP connections using Hayes-style commands. However, at the time there was almost no English-language documentation on the chip and the commands it accepted.^[2] The very low price and the fact that there were very few external components on the module which suggested that it could eventually be very inexpensive in volume, attracted many hackers to explore the module, chip, and the software on it, as well as to translate the Chinese documentation.^[3]

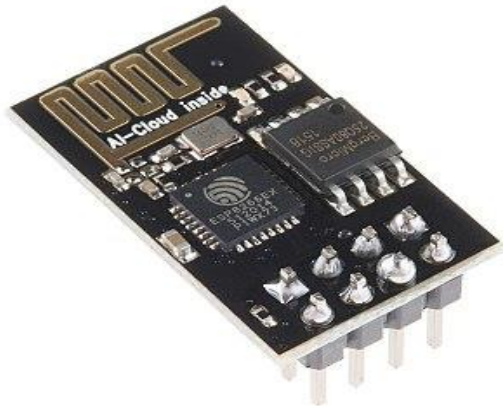

IV. PROJECT DESCRIPTION

This project ensures that the customers can easily identify the auto on off the water pump in different timings using RTC .

Block diagram:

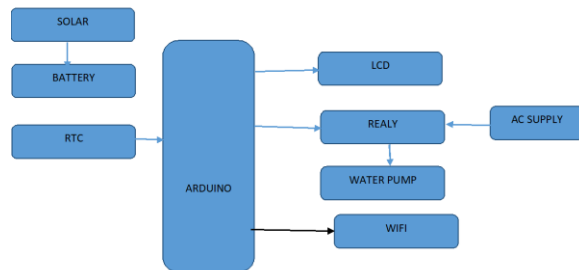

Working

The methodology adapted in implementation of this idea involves applying the simple concept of photovoltaicity to run the motors at different intervals of time. The applied methodology can be divided into three phases as follows: Phase 1 - In this phase the attributes of the projects are listed and some of the attributes that are meant to be fulfilled are listed as objectives. The list of objectives is again shortened to pruned objectives. These pruned objectives are chosen keeping in mind user demands and designer constraints. The system is designed to meet all these objectives. Some of the important objectives that the system should meet are safety, productivity, ease of use etc. Also the various constraints are taken into consideration like size and efficiency. Phase 2 – This phase includes finalizing the best suitable solutions from the number of solutions obtained from the

morphological chart. The morph chart in table 3.1 shows all the possible alternate solutions with the best ones being highlighted. The highlighted solutions are considered to be the best as well as suitable from the designer’s point of view. The morph chart shows the highlighted solutions like solar as source of energy, toggle button to turn on and off the system for user comfort , arm , Keil , embedded C as technical parts of system development, field and dc motors for betterment of product design. Phase 3 – The inputs and the outputs of the system are identified and they are applied to the black box. The figshows the black box having Solar energy and Push button at the inputs side . They are identified as the inputs to the system .Also the outputs are identified as Operation of pump, Flow of water to field area and sound . Though sound is an irrelevant output it is included in the fig to give a clear idea of all the possible outputs. Phase 4 – It involves the developing of the overall flow of the project .In this phase the components for the system development are listed taking their specifications into consideration. The detailed description of the components used is discussed in the implementation phase. The interconnectivity of the components is clearly shown in the fig.is called transparent box as it uncovers the black box which shows all the components involved in the system development.

V.CONCLUSION

In this project, we have presented water pumping technique using solar energy. The principle used is photovoltaicity. A solar panel is used that converts solar into electrical energy that is used to drive the water from the tank to the fields.The embed board is used for programming which controls the motors. In order to optimize the use of energy solar cell is used. It is shown that the water can be managed efficiently. Finally we can conclude that this project is user-friendly and can be operated on use of solar energy. The future scope is to include a level sensor that will indicate the level of water in the tank .

REFERENCES

[1]. International Journal of Emerging Technology and Advanced Engineering Website: www.ijetae.com (ISSN 2250-2459, ISO 9001:2008 Certified Journal, Volume 4, Issue 4, April 2014)

- [2]. Implementation of a High efficiency and low Cost Converter for a Photovoltaic Water Pumping System João Victor M. Caracas, Luis Felipe M. Teixeira , Guilherme de C. Farias , Luiz A. de S. Ribeiro, Institute of Electrical Energy Federal University of Maranhao Sao Luis, Brazil
- [3]. Optimization and Control of a Photovoltaic Powered Water Pumping System A. Chikh, IEEE and A. Chandra,IEEE.
- [4]. Distillate control to reduce electricity consumption in a solar multi-effect plant Lidia Roca, Luis J.Yebra CIEMATPlataforma Solar de Almer´ia, Tabernas, Almer´ia, Spain.
- [5]. WATER PUMPING FROM PHOTOVOLTAIC CELLS USING A CURRENT-FED PARALLEL RESONANT PUSH-PULL INVERTER System Apparent Power RMS Voltage Denizar Cruz Martins, Marcello Mezaroba, Ricardo Ruther and Ivo Barbi Federal University of Santa Catarina Department of Electrical Engineering Power Electronics Institute – INEP P.O. BOX 51 19 - 88040-970
- [6]. .Supplementary Load Frequency Control by Use of a Number of Both Electric Vehicles and Heat Pump Water Heaters Taisuke Masuta, StudentMember, IEEE, and Akihiko Yokoyama, Member, IEEE
- [7]. Challenges and Opportunities of Automation System for Water and Waste Water Applications Pradnya Gaonkar ABB Corporate Research Centre Bangalore, Karnataka, India pradnya.gaonkar@in.abb.com Mallikarjun Kande ABB Corporate Research Centre Bangalore, Karnataka, India.
- [8]. Design and Development of Precision Agriculture System Using Wireless Sensor Network S. R. Nandurkar Lecturer, Department of Instrumentation Engg., SGGSI&T, Nanded Nanded, (MS) India431606 sweetynandurkar11@gmail.com