

# Simulation Testing of Harmonic Reduction in SHPF-TCR Compensator in Comparison with Steady State Response and Dynamic State Response

**B.Prasanna Lakshmi**  
Department of EEE,  
Research Scholar,  
JNTU Anantapur,  
Anantapur, Andhra Pradesh, India

---

## ABSTRACT

This paper proposes the implementation of the comparative analysis of the with conventional power system arrangement to the steady state and dynamic state of the a combined system of a Thyristor-controlled reactor (TCR) and a shunt hybrid power filter (SHPF), for the process of limiting the total harmonic reduction is proposed in this paper. Total Circuit Configuration Is Simulated Using MATLAB 2012a And It Is Analyzed In Power Graphical User Interfacing Environment And The Total Harmonic Distortion Is Calculated By The Use Of The Fast Fourier Transformation Technique In POWERGUI,

**Keywords:** Harmonic suppression, hybrid power filter, modeling, nonlinear control, reactive power compensation, shunt hybrid power filter and thyristor-controlled reactor (SHPF-TCR compensator), thyristor-controlled reactor (TCR).

---

## INTRODUCTION

DUE to uncertainty of system loads on different feeders, which vary from time to time, the operation and control of distribution systems is more complex particularly in the areas where load density is high. Power loss in a distributed network will not be minimum for a fixed network configuration for all cases of varying loads. Hence, there is a need for reconfiguration of the network from time to time. Network reconfiguration is the process of altering the topological structure of feeders by changing open/closed status of sectionalizing and tie switches. In general, networks are reconfigured to reduce real power loss and to relieve overload in the network. However, due to dynamic nature of loads, total system load is more than its generation capacity that makes relieving of load on the feeders not possible and hence voltage profile of the system will not be improved to the required level. In order to meet required level of load demand, DG units are integrated in distribution network to improve voltage

profile, to provide reliable and uninterrupted power supply and also to achieve economic benefits such as minimum power loss, energy efficiency and load leveling. To date, network reconfiguration and DG placement in distribution networks are considered independently. However, in the proposed method, network reconfiguration and DG installation are dealt simultaneously for improved loss minimization and voltage profile.

In this paper, a new combination of a shunt hybrid power filter (SHPF) and a TCR (SHPF-TCR

compensator) is proposed to suppress current harmonics and compensate the reactive power generated from the load. The hybrid filter consists of a series connection of a small-rated active filter and a fifth-tuned LC passive filter. In the proposed topology, the major part of the compensation is supported by the passive filter and the TCR while the APF is meant to improve the filtering characteristics and damps the resonance, which can occur between the passive filter, the TCR, and the source impedance. The shunt APF when used alone suffers from the high kilo volt ampere rating of the inverter, which requires a lot of energy stored at high dc-link voltage. On the other hand, as published by some authors [15], the standard hybrid power filter is unable to compensate the reactive power because of the behavior of the passive filter. Hence, the proposed combination of SHPF and TCR compensates for unwanted reactive power and harmonic currents. In addition, it reduces significantly the voltampere rating of the APF part. The control method of the combined compensator is presented.

A control technique is proposed to improve the dynamic response and decrease the steady-state error of the TCR. It consists of a PI controller and a lookup table to extract the required firing angle to compensate a reactive power consumed by the load. A nonlinear control of SHPF is developed for current tracking and voltage regulation purposes. It is based on a decoupled control strategy, which considers that the controlled system may be divided into an inner fast loop and an outer slow one. The currents injected by the SHPF are controlled in the synchronous orthogonal dq frame using a decoupled feedback linearization control method. The dc bus voltage is regulated using an output feedback linearization control. The SHPF can maintain the low level of dc bus voltage at a stable value below 50 V. The proposed nonlinear control scheme has been simulated and validated experimentally to compute the performance of the proposed SHPF-TCR compensator with harmonic and reactive power compensation and analysis through the total harmonic distortion (THD) of the source and the load current. The proposed methodology is tested for a wide range of loads as discussed further. Simulation and experimental results show that the proposed topology is suitable for harmonic suppression and reactive compensation.

## **SIMULATION RESULTS**

The Total Circuit Configuration Is Simulated Using MATLAB 2012a And It Is Analyzed In Power Graphical User Interfacing Environment And The Total Harmonic Distortion Is Calculated By The Use Of The Fast Fourier Transformation Technique In POWERGUI, The Following Result Represents The A Combined System Of A Thyristor-Controlled Reactor (TCR) And A Shunt Hybrid Power Filter (SHPF) For Harmonic And Reactive Power Compensation. The SHPF Is The Combination Of A Small-Rating Active Power Filter (APF) And A Fifth-Harmonic-Tuned LC Passive Filter. The Tuned Passive Filter And The TCR Form A Shunt Passive Filter (SPF) To Compensate Reactive Power. The Small-Rating APF Is Used To Improve The Filtering Characteristics Of SPF And To Suppress The Possibility Of Resonance Between The SPF And Line Inductances. A Proportional-Integral Controller Was Used, And A Triggering Alpha Was Extracted Using A Lookup Table To Control The TCR. A Nonlinear Control Of APF Was Developed For Current Tracking And Voltage Regulation, The following tabular form represents the different electrical parameters of the source, transmission and load end.

The system parameters are given in Table I. Simulations were performed numerically using the “Power System Blockset” simulator operating under Matlab/Simulink environment, in order to verify the operation of the proposed SHPF-TCR compensator using the nonlinear control scheme shown in Figs. 1 and 5. The controller’s performance has been evaluated by achieving a number of tests on the proposed SHPF-TCR compensator:

1. steady-state response of the SHPF-TCR compensator to load-generating harmonics;
2. Dynamic response of the SHPF-TCR compensator to harmonic-produced load variations; and
3. Response of the SHPF-TCR compensator to the harmonic and reactive power type of load variation.

In this paper, a SHPF-TCR compensator of a TCR and a SHPF has been proposed to achieve harmonic elimination and reactive power compensation. A proposed nonlinear control scheme of a SHPF-TCR compensator has been established, simulated, and implemented by using MATLAB.

Tabular form 1. parameters used in simulation.

Line to Line source voltage, and frequency	$V_{s-L,L}=208 V, f_s=60 Hz$
Line impedance	$L_s=0.5 mH, R_s=0.1 \Omega$
Non linear load	$L_{L,1}=10 mH, R_{L,1}=27 \Omega,$
Linear load	$L_{L,2}=20 mH, R_{L,2}=27 \Omega$
Passive filter parameters	$L_{pf}= 1.2 mH, C_{pf}=240 \mu F$
Active filter parameters	$C_{dc}=3000 \mu F, R_{dc}=1k \Omega$
DC bus voltage of APF of SHAF	$V_{dc}=50 V$
Switching frequency	1920 Hz
Inner controller parameters	$K_{p1}=K_{p2}=43.38 ;$ $K_{i1}=K_{i2}=37408$
Outer controller parameters	$K_1=0.26 ; K_2=42$
Cut off frequency of the low pass filters	$F_c=70 Hz$
TCR inductance	$L_T= 25 mH$

The following circuit represents the circuit configuration of the general circuit without Shunt Hybrid Power Filter and Thyristor-Controlled Reactor in steady state condition and the following figure represents the complete MATLAB based results in POWERGUI environment.

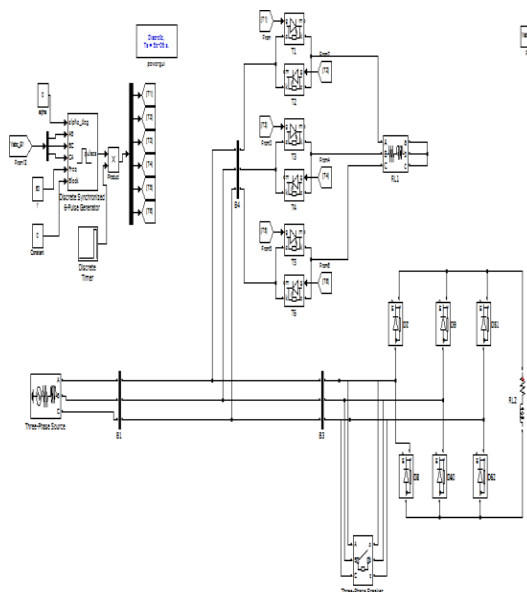

Figure 3. conventional circuit configuration

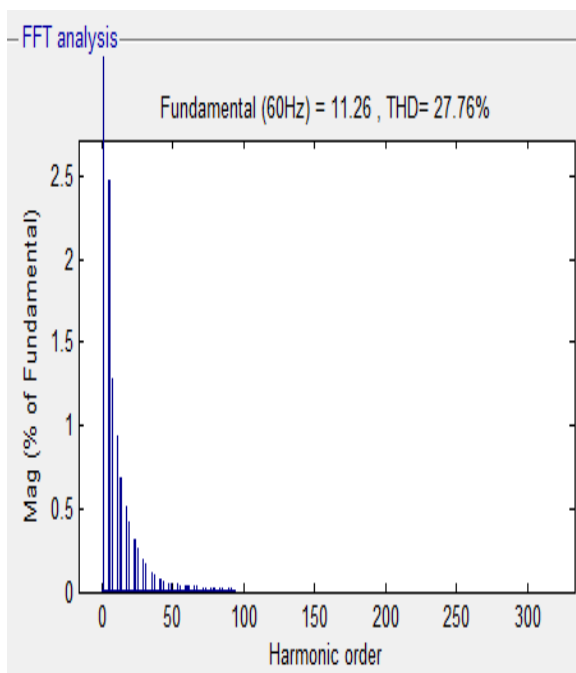

Figure 4. harmonic order for the conventional circuit configuration.

The following circuit represents the circuit configuration of the A Combination of Shunt Hybrid Power Filter and Thyristor-Controlled Reactor in steady state condition and the following figure represents the complete MATLAB based results in POWERGUI environment.

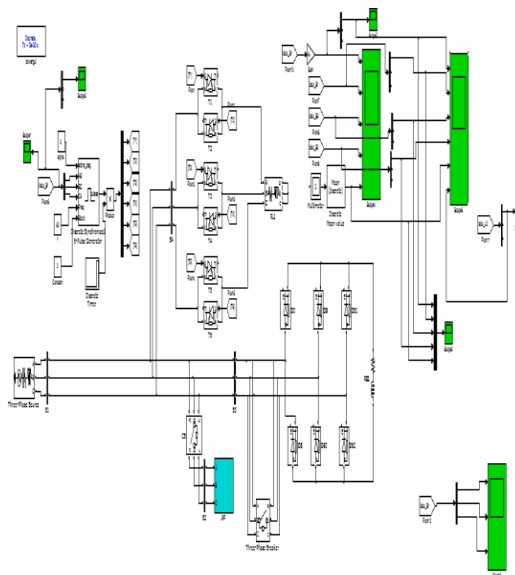

Figure 4. A Combination of Shunt Hybrid Power Filter and Thyristor-Controlled Reactor in steady state condition

Below Figure shows the steady-state waveform of the SHPF-TCR compensator for harmonic elimination with a three-phase harmonic-produced load. The supply voltage ( $v_{s1}$ ), the supply current ( $i_{s1}$ ), the load current ( $i_{L1}$ ), the SHPF-TCR current ( $i_{c1}$ ) in phase 1, and the dc bus voltage ( $v_{dc}$ ) are depicted in this figure.

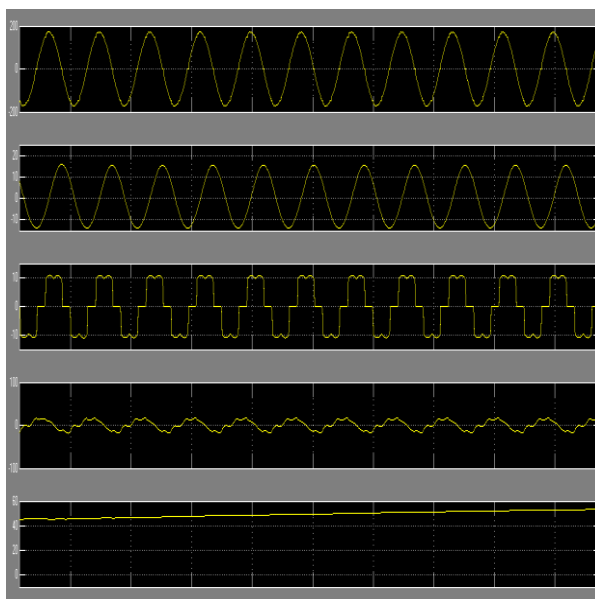

Figure 4. wave form representation of A Combination of Shunt Hybrid Power Filter and Thyristor-Controlled Reactor in steady state condition

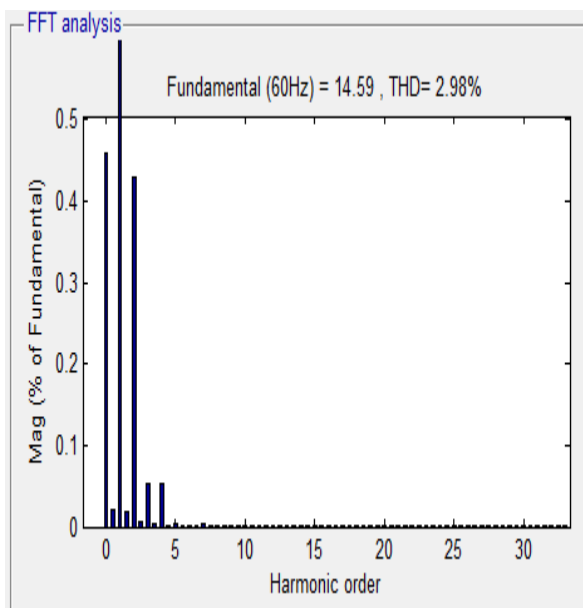

Figure 5. harmonic order A Combination of Shunt Hybrid Power Filter and Thyristor-Controlled Reactor in steady state condition

The following circuit represents the circuit configuration of the A Combination of Shunt Hybrid Power Filter and Thyristor-Controlled Reactor in dynamic state condition and the following figure represents the complete MATLAB based results in POWERGUI environment.

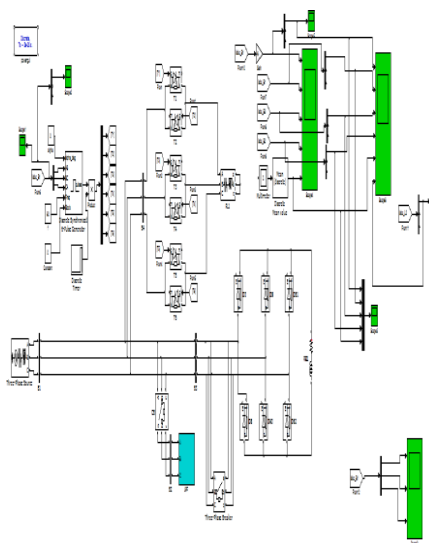

Figure 6. circuit configuration of A Combination of Shunt Hybrid Power Filter and Thyristor-Controlled Reactor in dynamic state condition

Below Figure shows the steady-state waveform of the SHPF-TCR compensator for harmonic elimination with a three-phase harmonic-produced load. The supply voltage (vs1), the supply current (is1), the load current (iL1), the SHPF-TCR current (ic1) in phase 1, and the dc bus voltage (vdc) are depicted in this figure.

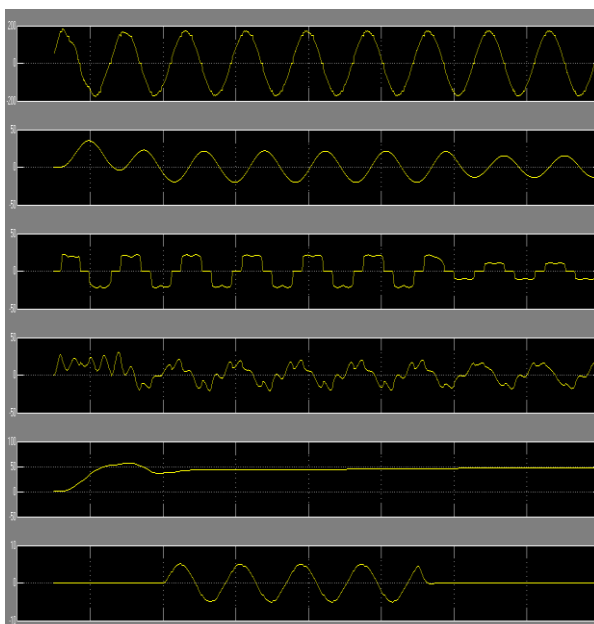

Figure 7. MATLAB based waveforms of A Combination of Shunt Hybrid Power Filter and Thyristor-Controlled Reactor in dynamic state condition

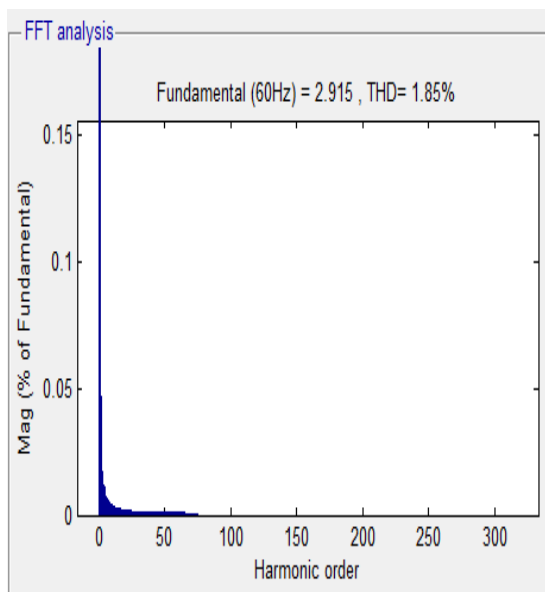

Figure 8. harmonic order A Combination of ShuntHybrid Power Filter and Thyristor-Controlled Reactor in dynamic state condition

CONCLUSION

This paper proposes the restraining of the total harmonic distortion of the conventional power system. And matlab based modeling of the conventional power system is proposed and the MATLAB based modeling of the steady and dynamic state operation of this convention power system with hybrid power filter is also proposes successfully in this paper.

## REFERENCES

- [1]. A. Hamadi, S. Rahmani, and K. Al-Haddad, "A hybrid passive filter configuration for VAR control and harmonic compensation," *IEEE Trans. Ind. Electron.*, vol. 57, no. 7, pp. 2419-2434, Jul. 2010.
- [2]. P. Flores, J. Dixon, M. Ortuzar, R. Carmi, P. Barriuso, and L. Moran, "Static Var compensator and active power filter with power injection capability, using 27-level inverters and photovoltaic cells," *IEEE Trans. Ind. Electron.*, vol. 56, no. 1, pp. 130-138, Jan. 2009.
- [3]. H. Hu, W. Shi, Y. Lu, and Y. Xing, "Design considerations for DSP-controlled 400 Hz shunt active power filter in an aircraft power system," *IEEE Trans. Ind. Electron.*, vol. 59, no. 9, pp. 3624-3634, Sep. 2012.
- [4]. X. Du, L. Zhou, H. Lu, and H.-M. Tai, "DC link active power filter for three-phase diode rectifier," *IEEE Trans. Ind. Electron.*, vol. 59, no. 3, pp. 1430-1442, Mar. 2012.
- [5]. M. Angulo, D. A. Ruiz-Caballero, J. Lago, M. L. Heldwein, and S. A. Mussa, "Active power filter control strategy with implicit closedloop current control and resonant controller," *IEEE Trans. Ind. Electron.*, vol. 60, no. 7, pp. 2721-2730, Jul. 2013.
- [6]. X. Wang, F. Zhuo, J. Li, L. Wang, and S. Ni, "Modeling and control of dual-stage high-power multifunctional PV system in d-q-0 coordinate," *IEEE Trans. Ind. Electron.*, vol. 60, no. 4, pp. 1556-1570, Apr. 2013.
- [7]. J. A. Munoz, J. R. Espinoza, C. R. Baier, L. A. Moran, E. E. Espinosa, P. E. Melin, and D. G. Sbarbaro, "Design of a discrete-time linear control strategy for a multicell UPQC," *IEEE Trans. Ind. Electron.*, vol. 59, no. 10, pp. 3797-3807, Oct. 2012.
- [8]. L. Junyi, P. Zanchetta, M. Degano, and E. Lavopa, "Control design and implementation for high performance shunt active filters in aircraft power grids," *IEEE Trans. Ind. Electron.*, vol. 59, no. 9, pp. 3604-3613, Sep. 2012.
- [9]. Y. Tang, P. C. Loh, P. Wang, F. H. Choo, F. Gao, and F. Blaabjerg, "Generalized design of high performance shunt active power filter with output LCL filter," *IEEE Trans. Ind. Electron.*, vol. 59, no. 3, pp. 1443-1452, Mar. 2012.
- [10]. Z. Chen, Y. Luo, and M. Chen, "Control and performance of a cascaded shunt active power filter for aircraft electric power system," *IEEE Trans. Ind. Electron.*, vol. 59, no. 9, pp. 3614-3623, Sep. 2012.
- [11]. S. Rahmani, A. Hamadi, K. Al-Haddad, and A. I. Alolah, "A DSP-based implementation of an instantaneous current control for a three-phase shunt hybrid power filter," *J. Math. Comput. Simul.-Model. Simul. Elect. Mach., Convert. Syst.*, vol. 91, pp. 229-248, May 2013.
- [12]. C. S. Lam, W. H. Choi, M. C. Wong, and Y. D. Han, "Adaptive dc-link voltage-controlled hybrid active power filters for reactive power compensation," *IEEE Trans. Power Electron.*, vol. 27, no. 4, pp. 1758-1772, Apr. 2012.
- [13]. A. Hamadi, S. Rahmani, and K. Al-Haddad, "Digital control of hybrid power filter adopting nonlinear control approach," *IEEE Trans. Ind. Informat.*, to be published.
- [14]. A. Bhattacharya, C. Chakraborty, and S. Bhattacharya, "Parallelconnected shunt hybrid active power filters operating at different switching frequencies for improved performance," *IEEE Trans. Ind. Electron.*, vol. 59, no. 11, pp. 4007-4019, Nov. 2012.



- [15]. S. Rahmani, A. Hamadi, N.Mendalek, and K. Al-Haddad, "A new control technique for three-phase shunt hybrid power filter," *IEEE Trans. Ind. Electron.*, vol. 56, no. 8, pp. 2904-2915, Aug. 2009.
- [16]. A. Luo, X. Xu, L. Fang, H. Fang, J. Wu, and C. Wu, "Feedbackfeedforward PI-type iterative learning control strategy for hybrid active power filter with injection circuit," *IEEE Trans. Ind. Electron.*, vol. 57, no. 11, pp. 3767-3779, Nov. 2010.
- [17]. S. Rahmani, A. Hamadi, and K. Al-Haddad, "A Lyapunov-function-based control for a three-phase shunt hybrid active filter," *IEEE Trans. Ind. Electron.*, vol. 59, no. 3, pp. 1418-1429, Mar. 2012.
- [18]. M. I. Milanés-Montero, E. Romero-Cadaval, and F. Barrero-González, "Hybrid multiconverter conditioner topology for high- power applications," *IEEE Trans. Ind. Electron.*, vol. 58, no. 6, pp. 2283-2292, Jun. 2011.
- [19]. C. A. Silva, L. A. Cordova, P. Lezana, and L. Empringham, "Implementation and control of a hybrid multilevel converter with floating dc links for current waveform improvement," *IEEE Trans. Ind. Electron.*, vol. 58, no. 6, pp. 2304-2312, Jun. 2011.
- [20]. A. Luo, S. Peng, C. Wu, J. Wu, and Z. Shuai, "Power electronic hybrid system for load balancing compensation and frequency- selective harmonic suppression," *IEEE Trans. Ind. Electron.*, vol. 59, no. 2, pp. 723-732, Feb. 2012.
- [21]. A. Luo, Z. Shuai, W. Zhu, and Z. John Shen, "Combined system for harmonic suppression and reactive power compensation," *IEEE Trans. Ind. Electron.*, vol. 56, no. 2, pp. 418-428, Feb. 2009.