

## A Realtime Voice Controlled Wheelchair for Specially Abled People

Dr. K. Sravan Kumar<sup>1</sup>, Pamanji Deepika<sup>2</sup>, Mahamad Farzana<sup>2</sup>, Ojja Kaveri<sup>2</sup>, Kumari Preethi<sup>2</sup>, Pemmaraju Bharati Sai Sailaja<sup>2</sup>

<sup>1</sup>Associate Professor, Dept. of ECE, Geethanjali Institute of Science and Technology, Nellore, Andhra Pradesh, India

<sup>2</sup>UG Student, Dept. of ECE, Geethanjali Institute of Science and Technology, Nellore, Andhra Pradesh, India

---

### Abstract

This abstract presents a novel solution for physically challenged individuals, specifically those who rely on wheelchairs for mobility. The proposed solution involves the development of a voice-controlled real-time wheelchair system, which is complemented by a mobile application. The system utilizes the HC-05 Bluetooth module, an Arduino UNO microcontroller, high torque DC motors, a 20A motor driver circuit, and a 12V, 7Amp battery. The objective of this project is to enhance the mobility and independence of physically challenged individuals by providing them with an easy-to-use and efficient wheelchair control mechanism. The system aims to provide enhanced control and convenience to users, enabling them to operate their wheelchairs more effectively and efficiently. The wheelchair system utilizes Bluetooth technology to establish a wireless connection between the wheelchair and a mobile device, such as a smartphone or tablet. This connection allows users to control the wheelchair's movements remotely, eliminating the need for physical contact with the wheelchair controls. The mobile application serves as the user interface, providing intuitive and customizable controls that cater to individual user needs and preferences.

**Keywords:** wheelchair control mechanism, Arduino UNO, HC-05 module, motor driver circuit, high torque DC motors.

---

### 1. Introduction

People with physical disabilities often face numerous challenges in their day-to-day activities, particularly in terms of mobility. Traditional manual wheelchairs have limitations in terms of manoeuvrability and control, which can hinder the independence and overall well-being of individuals with physical disabilities. To address these limitations, there is a pressing need for advanced assistive technologies that allow users to have better control over their wheelchair's movement, ensuring safe and efficient navigation in various environments. Assistive technology plays a crucial role in enhancing the quality of life for individuals with physical disabilities. Among various assistive devices, wheelchairs serve as a lifeline for those who have limited mobility. In recent years, advancements in technology have paved the way for innovative solutions that aim to empower physically challenged individuals by providing them with greater independence and control. This paper introduces a Bluetooth controlled real-time wheelchair, integrated with a mobile application, designed specifically to cater to the needs of individuals with physical disabilities. It holds immense significance as it harnesses the power of modern technology to provide enhanced mobility options for physically challenged individuals. By incorporating Bluetooth connectivity and a mobile application interface, users can conveniently operate and control their wheelchairs wirelessly, eliminating the need for physical exertion and manual handling. This technology offers greater freedom and independence to individuals with physical disabilities, empowering them to navigate their surroundings with ease and confidence.

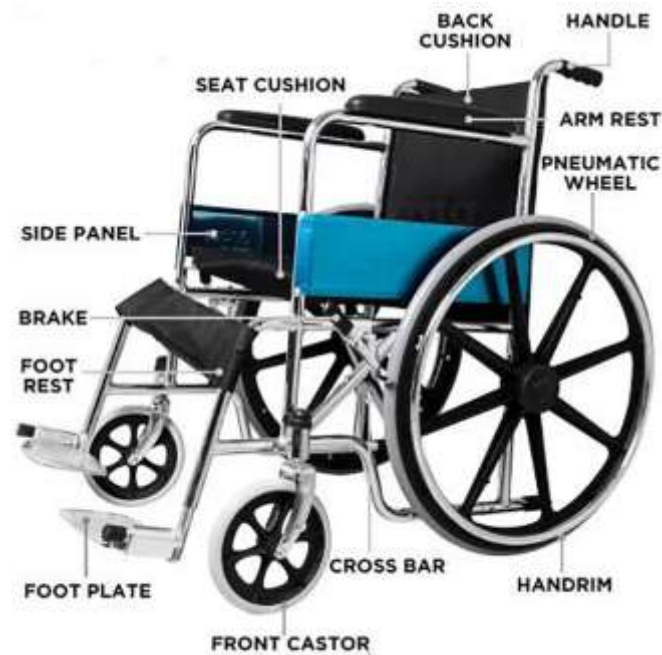

Figure 1: Sample wheelchair of Entros 809B SC (Source: Tata 1mg).

This research makes several key contributions to the field of assistive technology for physically challenged individuals. Firstly, it presents a comprehensive design and implementation of a Bluetooth controlled real-time wheelchair, integrating essential components such as the HC-05 Bluetooth module, a 12V, 7Amp battery, an Arduino UNO microcontroller, high torque DC motors, a 20A motor driver circuit, and a 3D printed control panel. The developed mobile application provides an intuitive user interface for controlling the wheelchair's movement, offering features like speed adjustment, direction control, and emergency stop functionality. Furthermore, the study explores the mechanical design considerations, ensuring optimal comfort and safety for the wheelchair user. The project's cost-effectiveness and feasibility are also addressed, allowing for potential scalability and widespread adoption. Overall, this research aims to enhance the mobility and independence of physically challenged individuals through the integration of modern technology, providing a practical and reliable solution that addresses their unique needs and challenges.

### 1.1 Problem definition

The primary challenge addressed by this research is to design and develop a Bluetooth controlled real-time wheelchair that caters specifically to the needs of physically challenged individuals. The wheelchair should offer seamless and intuitive control mechanisms, allowing users to manoeuvre effortlessly through various terrains and environments. Additionally, the system should be cost-effective, reliable, and easy to use, ensuring its practicality and accessibility for a wide range of users.

## 2. Related work

Kumaran, and Renold described the implementation of a voice-based wheelchair system for individuals with disabilities [1]. It likely discusses the integration of voice recognition technology to enable wheelchair control through voice commands. The conference paper provides insights into the design, development, and evaluation of the voice-based wheelchair system. Wanluk et al. [2] focused on a smart wheelchair that utilizes eye-tracking technology for control. The paper likely explores the integration of eye-tracking sensors and algorithms to enable individuals with disabilities, specifically those with limited motor control, to operate the wheelchair through eye movements. The conference

paper presents the design, implementation, and evaluation of the eye-tracking-based smart wheelchair system.

Aruna et al. [3] discussed a wheelchair system that combines voice recognition and touch screen control for individuals with paraplegia. The paper likely explores the integration of voice recognition technology and a touch screen interface to provide users with multiple control options. The conference paper presents the design, implementation, and performance evaluation of the voice recognition and touch screen-based wheelchair system. Chauhan et al. [4] presented a study on the implementation of a voice-controlled wheelchair system. The paper likely discusses the design considerations, hardware components, and software algorithms used to enable wheelchair control through voice commands. The conference paper may also include performance evaluations and user feedback on the voice-controlled wheelchair system.

In [5], it refers to the official data collected by the Census of India in 2021 regarding disability. It provides statistical information about the prevalence of disabilities in India, including various categories and types of disabilities. The data serves as a valuable resource for researchers, policymakers, and organizations involved in disability-related initiatives and programs. In [6], The World Health Organization (WHO) published the "World report on Disability," which presents a comprehensive overview of disability globally. The report addresses the prevalence, impact, and barriers faced by people with disabilities, as well as their rights and inclusion. It provides insights into the challenges and strategies for improving the lives of individuals with disabilities and promoting their full participation in society. In [7], Simpson focused on smart wheelchairs and discusses various studies, advancements, and technologies related to smart wheelchair systems. It provides a comprehensive overview of the state-of-the-art in smart wheelchair research at the time, including sensing, control, navigation, and user interface aspects. In [8], Parikh, et al. discussed the integration of human inputs with autonomous behaviors on an intelligent wheelchair platform. It explores the development of a system that combines user control and autonomous capabilities, allowing the wheelchair to adapt to user commands while also providing intelligent navigation and obstacle avoidance. Ruzaj and Poonguzhali [9], focused on the design and implementation of a low-cost intelligent wheelchair. It discusses the development of an affordable intelligent wheelchair system, including the integration of sensors, control mechanisms, and user interface components. In [10] Klabi, et al. focused on advanced user interfaces for intelligent wheelchair systems. It explores innovative approaches and technologies for enhancing the user interface of intelligent wheelchairs, aiming to improve the user experience and enable more intuitive and efficient control of the wheelchair's functionalities.

Abid et al. [11] presented the design and development of a Bluetooth controlled electric wheelchair. It discusses the integration of Bluetooth technology to enable wireless control of the wheelchair using a mobile application. The study highlights the implementation and functionality of the system. Pandey et al. [12] focused on the development of a Bluetooth controlled wheelchair for physically disabled individuals. It describes the design and implementation of the system, emphasizing the wireless control aspect using Bluetooth technology. The study explores the practicality and usability of the wheelchair for the intended user group. Li et al. [13] discussed the design and implementation of a Bluetooth-based smart wheelchair for disabled people. It presents the integration of Bluetooth technology for remote control of the wheelchair through a mobile application. The paper highlights the features and functionalities of the system, focusing on improving the mobility and independence of physically challenged individuals.

Subramanian et al. [14] presented a smartphone-based Bluetooth controlled wheelchair specifically designed for physically disabled people. It outlines the development of the wheelchair system,

emphasizing the integration of Bluetooth connectivity and the use of a smartphone as a control interface. The study evaluates the performance and usability of the wheelchair through experimental results. Bafagih et al. [15] focused on the design and development of a Bluetooth-controlled smart wheelchair tailored for physically disabled individuals. It discusses the technical aspects of the system, including the integration of Bluetooth technology and the development of a mobile application for controlling the wheelchair. The study emphasizes the importance of user-centric design and evaluates the wheelchair's performance and usability through user feedback and testing.

### 3. Existing system

A wheelchair is a device used for transportation by the disabled and the elderly. There are several types of smart wheelchairs on the market. In some cases, for example, a person with Amyotrophic Lateral Sclerosis (ALS) or Parkinson's disease, it may be extremely difficult or unusual for such a patient to use a standard type of framework. They are based on motion, eye position, Bluetooth recognition, brain waves, and so on. A self-propelled manual wheelchair incorporates a casing, seat, perhaps a few footplates (footstools), and four wheels: typically, two caster wheels in front and two large wheels in back. They created the control system, which includes both software and hardware. Bluetooth-controlled posture change and driving were achieved, the hardware circuit and software program were tested and debugged, and Bluetooth control of the wheelchair recognition rates for the same individual were satisfactory. Nevertheless, because it recognizes a large number of Bluetooth devices, it cannot be used in congested areas.

### 4. Proposed system

The Bluetooth-controlled real-time wheelchair for physically challenged people combines various components and technologies to enable remote control and real-time monitoring. Let's explore the working and methodology of this system using the components mentioned in Figure 2.

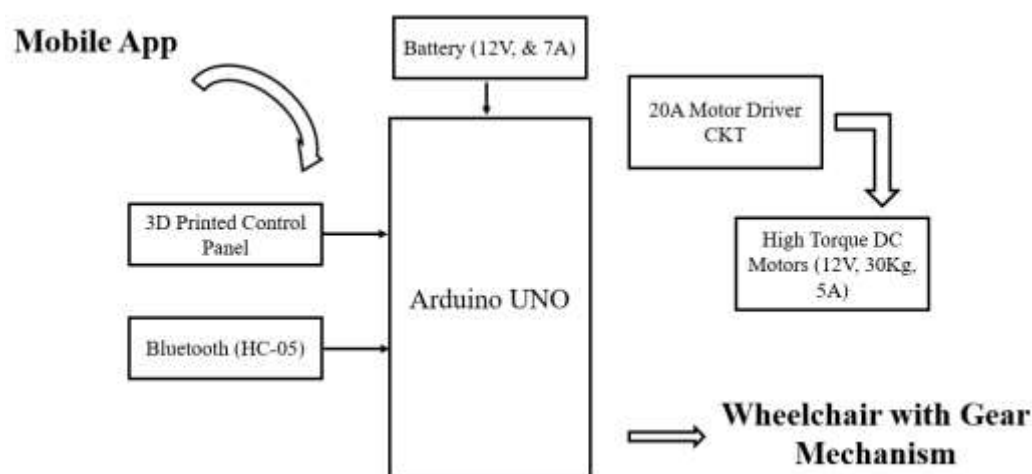

Figure 2: Proposed block diagram of voice controlled real-time wheelchair with gear mechanism.

#### 4.1 Working

Wheelchair: The wheelchair serves as the base structure that provides mobility to the user. It incorporates a sturdy frame, comfortable seating, and wheels suitable for indoor and outdoor use. The wheelchair is modified to accommodate the electronic components and mechanisms necessary for remote control.

**Battery 12V, 7A:** The battery supplies power to the entire system. It is a 12V, 7Amp battery, chosen for its capacity to deliver sufficient power to the high torque DC motors and other electronic components.

**High torque DC motors 12V, 30Kg, 5A:** The high torque DC motors are responsible for propelling the wheelchair. They are specifically selected for their ability to generate enough torque to move the wheelchair and carry the weight of the user. These motors operate at 12V and draw a maximum of 5A current.

**Motor bracket 3mm:** The motor bracket provides a secure mounting platform for the high torque DC motors. It is a 3mm thick bracket designed to ensure stability and durability while holding the motors in place.

**Voltage Display:** The voltage display is an electronic module that measures and displays the voltage level of the battery. It provides a visual indication of the remaining battery power, allowing the user to monitor the battery status.

**3D printed Control panel (PLA material):** The control panel is a user interface component that houses various controls and switches. It is 3D printed using PLA (Polylactic Acid) material, known for its durability and ease of customization. The control panel provides a convenient and accessible platform for the user to interact with the wheelchair.

**Battery charging socket:** The battery charging socket allows the user to connect an external power source for recharging the battery. It provides a safe and standardized interface for charging the battery when needed.

**On/Off switch:** The On/Off switch is a simple toggle switch that controls the power supply to the entire system. It allows the user to turn the wheelchair on or off as required.

**Reset button:** The reset button is a small push-button switch that resets the system to its default state. It is useful in case of any malfunction or system error, allowing the user to restart the wheelchair's control system.

**4mm mild steel Gears 2 (left and right):** The mild steel gears are crucial components in the wheelchair's drivetrain. They are responsible for transmitting the rotational motion of the DC motors to the wheels, enabling the wheelchair's movement. The gears are made of 4mm thick mild steel to ensure durability and efficiency.

**20A motor driver circuit:** The 20A motor driver circuit controls the power supply and direction of the high torque DC motors. It acts as an interface between the microcontroller and the motors, receiving signals from the control system and regulating the motor currents accordingly. The 20A rating ensures the circuit can handle the current requirements of the motors.

**HC-05 Bluetooth module:** The HC-05 Bluetooth module enables wireless communication between the wheelchair and a mobile device, such as a smartphone or tablet. It receives voice commands from the mobile application and relays them to the microcontroller, allowing the user to control the wheelchair remotely. The Bluetooth module ensures a reliable and low-power connection for seamless communication.

## 4.2 Methodology

The methodology for the voice-controlled real-time wheelchair involves integrating the mentioned components into a functional system. The high torque DC motors are securely mounted on the motor bracket and connected to the 20A motor driver circuit. The motor driver circuit receives control signals from the microcontroller and regulates the motor currents, accordingly, controlling the

wheelchair's movement. The microcontroller, such as the Arduino UNO, acts as the brain of the system. It receives voice commands from the mobile app via HC-05 Bluetooth module. The microcontroller processes these voice commands and sends corresponding signals to the motor driver circuit to control the motors' speed and direction.

The mobile application, developed for smartphones or tablets, establishes a Bluetooth connection with the HC-05 module. It provides an intuitive user interface, allowing the user to send voice commands to the wheelchair, such as forward, backward, left, right, or stop. The voltage display, battery charging socket, On/Off switch, and reset button provide additional control and monitoring functionalities, enhancing the usability and safety of the wheelchair. To ensure proper mechanical integration and customization, the 3D printed control panel is designed to house the necessary controls and switches. It is strategically positioned on the wheelchair to provide easy access and intuitive operation for the user. Overall, the methodology involves careful assembly and integration of the components, programming the microcontroller, developing the mobile application, and testing the system for functionality, reliability, and user-friendliness.

### 4.3 Operation

The system utilizes the HC-05 Bluetooth module, an Arduino UNO microcontroller, high torque DC motors, a 20A motor driver circuit, and a 12V, 7Amp battery. The objective of this project is to enhance the mobility and independence of physically challenged individuals by providing them with an easy-to-use and efficient wheelchair control mechanism. The wheelchair is equipped with a mobile application that allows users to control the movement of the wheelchair wirelessly through a Bluetooth connection. The HC-05 Bluetooth module enables seamless communication between the mobile application and the Arduino UNO microcontroller, which serves as the control unit for the wheelchair. The Arduino UNO receives voice commands from the mobile application and processes them to drive the high torque DC motors. To ensure the safe and reliable operation of the wheelchair, a 20A motor driver circuit is employed. This circuit acts as an interface between the Arduino UNO and the high torque DC motors, enabling precise control over the wheelchair's speed and direction. The 12V, 7Amp battery provides the necessary power to drive the motors and sustain the system's operation for an extended period.

Table 1: Wheelchair specifications.

Parameter	Dimension
Seat width	39cm
Height	100cm
Size from top handle to wheel	31cm
Size from front handle to wheel	40.4cm
Wheel diameter	50.6cm
Length of steel bar at base	40cm
Length of leg rest	30.6cm
Distance between each leg rest	10.5cm

## 5. Hardware Results and discussion

### 5.1 Bluetooth Module

HC-05 is a Bluetooth module which is designed for wireless communication. This module can be used in a master or slave configuration.

**Pin Description:** Bluetooth serial modules allow all serial enabled devices to communicate with each other using Bluetooth.

It has 6 pins,

**1. Key/EN:** It is used to bring Bluetooth module in AT commands mode. If Key/EN pin is set to high, then this module will work in command mode. Otherwise by default it is in data mode. The default baud rate of HC-05 in command mode is 38400bps and 9600 in data mode.

HC-05 module has two modes,

1. **Data mode:** Exchange of data between devices.

2. **Command mode:** It uses AT commands which are used to change setting of HC-05. To send these commands to module serial (USART) port is used.

**2. VCC:** Connect 5 V or 3.3 V to this Pin.

**3. GND:** Ground Pin of module.

**4. TXD:** Transmit Serial data (wirelessly received data by Bluetooth module transmitted out serially on TXD pin)

**5. RXD:** Receive data serially (received data will be transmitted wirelessly by Bluetooth module).

**6. State:** It tells whether module is connected or not.

### 5.2 Machining process with outcome











## 6. Conclusion

The integration of the mobile application with the voice-controlled wheelchair offers several advantages. Users can conveniently operate the wheelchair remotely, eliminating the need for physical contact with control buttons. The mobile application also provides the users with essential information for managing their mobility effectively. Overall, this voice-controlled real-time wheelchair with a mobile application addresses the specific needs of physically challenged individuals, providing them with a user-friendly and efficient means of controlling their wheelchair. The system's integration of modern technologies, such as Bluetooth and mobile applications, offers enhanced mobility, independence, and convenience for the user, ultimately improving their overall quality of life.

## References

- [1] M. B. Kumaran and A. P. Renold, "Implementation of voice-based wheelchair for differently abled," in 4th IEEE International Conference on Computing, Communication, and Networking Technologies, India, 2013, pp. 1-6.
- [2] N. Wanluk, S. Visitsattapongse, A. Juhong, and C. Pintavirooj, "Smart wheelchair based on eye tracking," in 9th IEEE Biomedical Engineering International Conference (BMEiCON), 2016.

- 
- [3] C. Aruna, P. Dhivya, M. Malini, and G. Gopu, "Voice recognition and touch screen control based wheelchair for paraplegic persons," in IEEE International Conference on Green Computing Communication and Electrical Engineering, India, 2014, pp. 1-5.
- [4] R. Chauhan, Y. Jain, H. Agarwal, and A. Patil, "Study of Implementation of voice controlled wheelchair," in 3rd International Conference on Advanced Computing and Communication Systems (ICACCS-2016), 2016.
- [5] Census of India 2021 "Data on Disability"
- [6] World Health Organization "World report on Disability"
- [7] R.C. Simpson, "Smart wheelchairs: a literature review," J. Rehabilitation Res. Dev., 2005.
- [8] S.P. Parikh, V. Grassi Jr., V. Kumar, and J. Okamoto Jr., "Integrating human inputs with autonomous behaviors on an intelligent wheelchair platform," in IEEE Computer Society, vol. 22, no. 2, pp. 33-41, Feb. 2007.
- [9] M.F. Ruzajj and S. Poonguzhali, "Design and Implementation of low cost intelligent wheelchair," in Proceedings of IEEE International Conference on Recent Trends in Information Technology, India, 2012, pp. 468-471.
- [10] I. Klabi, M.S. Masmoudi, and M. Masmoudi, "Advanced user interfaces for intelligent wheelchair system," in Proceedings of 1st IEEE Conference on Advanced Technologies for Signal and Image Processing, Tunisia, 2014, pp. 130-136.
- [11] T. Abid, A. Rashid, and A. Ashraf, "Design and development of a Bluetooth controlled electric wheelchair," International Journal of Advanced Computer Science and Applications, vol. 10, no. 5, pp. 541-545, 2019.
- [12] H. Pandey and N. Sharma, "Bluetooth controlled wheelchair for physically disabled people," International Journal of Scientific & Engineering Research, vol. 10, no. 4, pp. 224-228, 2019.
- [13] R. Li, Z. Yan, and H. Li, "Design and implementation of a Bluetooth-based smart wheelchair for disabled people," Journal of Ambient Intelligence and Humanized Computing, vol. 11, no. 2, pp. 583-592, 2020.
- [14] S. Subramanian, N. R. Dhinesh, and M. Ganesan, "Smartphone-based Bluetooth controlled wheelchair for physically disabled people," International Journal of Emerging Trends in Engineering Research, vol. 9, no. 9, pp. 4319-4324, 2021.
- [15] N. F. Bafagih, K. Alqurna, and M. Bafagih, "Design and development of a Bluetooth-controlled smart wheelchair for physically disabled people," Sensors, vol. 21, no. 2, p. 543, 2021.