

DESIGN AND FABRICATION OF VERTICAL AXIS WIND MILL POWER GENERATION

Arun, Dr.Mallikarjun R Vaggar, Sathishkumar,,Assistant Professor, Department of Mechanical
Engineering

Professor, Department of Aeronautical Engineering,Dhanalakshmi Srinivasan College of Engineering
and Technology, Mamallapuram.

ABSTRACT:

Novel approaches are needed to reduce growth in blade mass with blade length. With design focus on turbine mass and cost for given performance, need arises for passive and active techniques to control the flow and the loads on the blades/turbine. To maximize the overall system benefits of these techniques, load control should be included from the onset. This research uses a optimization technique using the micro-tabs and different materials like Steel , aluminum , GFRP composites is used to reduce such weight. The well-defined model of wind blade is created and this will undergo for the analysis by ansys software, and the results will compare with that of basic materials like steel and existing design. Also to reduce the weight optimization via making ribsalso is used to modify the flow characteristics and can give the controlled flow of wind which in fact to increases the aerodynamic efficiency by means of composite materials. The thin airfoil blade is designed and performed with Ansys for the different materials. With prototype fabrication of the wind blade was carried out. Due to this smart material like glass fibre reinforced plastic with aluminum the rotor torque will increased. With this effect the overall wind mill performance will increase.

INTRODUCTION;

However, it cannot carry a load with any efficiency; it has never been constructed on a large scale for use as a wind turbine. The Savonius rotor works on a principle similar to that of the cup

anemometer but is adopted to produce shaft power. It also takes advantage of the lift generated as the curved outer surfaces of its scoops cross the air flow.

There are also a variety of so-called Panamones; there are pure drag devices, in which one side of the rotor carries blades or sails square to the wind, while other side produces reducing drag by shielding or furling the blades. Because drag devices tend to run at TSR below unity (since their tips can not readily travel faster than the wind), they are inevitably less efficient than lift-dependent devices. In addition, their high solidity makes them more material-intensive in relation to the wind area 'seen' by the rotor.

Hence following are the three distinct advantages of vertical axis wind turbines over vertical axis ones:

- They will react to wind from any direction and therefore do not need yawing equipment to turn the rotor into the wind.
- They can require less structural support because heavy components (like gear box and generator) can be located at ground level. This configuration also eases installation and maintenance.
- Since the blades do not turn end over end, the rotor is not subjected to continuous cyclic gravity loads. (Fatigue induced by such action is a major consideration in the design of large vertical axis machines).

Properly the single biggest disadvantage with vertical axis machines is that far less is known about them than vertical axis ones. This handicap is rapidly being removed.

BLOCK DIAGRAM:

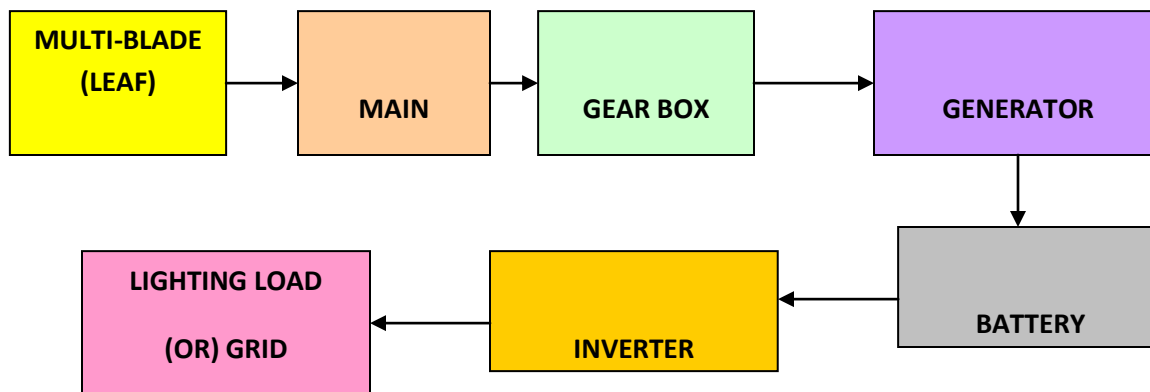

Wind result from air in motion. Air in motion arises from a pressure gradient. On a global basis one primary forcing function causing surface winds from the poles toward the equator is convective circulation. Solar radiation heats the air near the equator, and this low density heated air is buoyed up. At the surface it is displaced by cooler more dense higher pressure air flowing from the poles. In the upper atmosphere near the equator the air thus tend to flow back toward the poles and away from the equator. The net result is a global convective circulation with surface wins from north to south in the northern hemisphere.

LITERATURE REVIEW:

Theory and Evolutionary Computation” Andrea Toffolo Ernesto Benini. The Optimal Design of Horizontal-Axis Wind Turbines Using Blade-Elements paper describes a multi-objective optimization method for the design of stall regulated horizontal-axis wind turbines. Two modules are used for this purpose: anaerodynamic model implementing the blade-element theory and a multi-objective evolutionary algorithm. The former provides a sufficiently accurate solution of the flow field around the rotor disc; the latter handles the decision variables of the optimization problem, i.e., the main geometrical parameters of the rotor configuration, and promotes function optimization.

The scope of the method is to achieve the best trade-off performance between two objectives: annual energy production per square meter of Wind Park (to be maximized) and cost of energy (to be minimized). Examples of the best solutions found by the method are described and their performance compared with those of commercial wind turbines.

COMPONENTS AND DESCRIPTION:

Basic Components of a WECS (Wind Energy Conversion System)

The main components of a WECS are shown in Fig., in block diagram form. Summary of the system operation is as follows: Aero turbines convert energy in moving air to rotary mechanical energy. In general, they require pitch control and yaw control (only in the case of horizontal or wind axis machines) for proper operation. A mechanical interface consisting of a step up gear and a suitable coupling transmits the rotary mechanical energy to an electrical generator. The output of this generator is connected to the load or power grid as the application warrants.

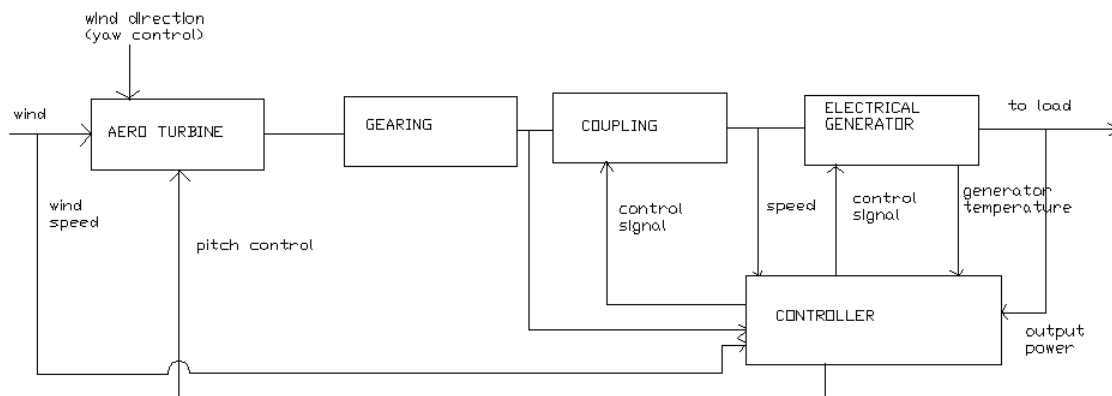

Yaw control. For localities with the prevailing wind in one direction, the design of the turbine can be greatly simplified. The rotor can be in a fixed orientation with the swept area perpendicular to the predominant wind direction. Such a machine is said to be yaw fixed. Most wind turbine, however, are yaw active that is to say, as the wind direction changes, a motor rotates the turbine slowly about the vertical (or yaw) axis so as to face the blades in to the wind. The area of the wind swept by the wind rotor is then a maximum. In a small turbine, yaw action is controlled by a tail van, similar to that in a typical windmill. In large machines, a servomechanism operated by a wind-direction sensor controls the yaw motor that keeps the turbine properly oriented. The purpose of the controller is to sense wind speed, wind direction, shafts speeds and torques at one or more points, output power and generator temperature as necessary and appropriate control signals for matching the electrical output to the wind energy input and project the system from extreme conditions brought upon by strong winds electrical faults, and the like.

The physical embodiment for such an areo-generator is shown in a generalized form. The sub-components of the windmill are:

- Wind turbine or rotor
- Wind mill head
- Transmission and control, and
- Supporting structure

Rotors

Rotors are mainly of two types:

- Horizontal axis rotor and
- Vertical axis rotor

One advantage of vertical – axis machines is that they operate in all wind directions and thus need no yaw adjustment. The rotor is only one of the important components. For an effective utilization, all the components need to be properly designed and matched with the rest of the components.

The windmill head supports the rotor, housing the rotor bearings. It also houses any control mechanism incorporated like changing the pitch of the blades

for safety devices and tail vane to orient the rotor to face the wind. The latter is facilitated by mounting it on the top of the supporting structure on suitable bearings.

TRANSMISSION:

Varying the pitch of the rotor blades, conveniently controls the rate of rotation of large wind turbine generators operating at rated capacity or below, but it is low, about 40 to 50 revolutions per minute (rpm).

Because optimum generator output requires much greater rates of rotation, such as 1800 rpm, it is necessary to increase greatly the low rotor of turning. Among the transmission options are mechanical systems involving fixed ratio gears, belts, and chains, singly or in combination or hydraulic systems involving fluid pumps and motors. Fixed ratio gears are recommended for top mounted equipment because of their high efficiency; know cost, and minimum system risk. For bottom mounted equipment which requires a right-angle drive, transmission costs might be reduced substantially by using large diameter bearings with ring gears mounted on the hub to serve as a transmission to increase rotor speed to generator speed. Such a combination offers a high degree of design flexibility as well as large potential saving.

Generator :

Either constant or variable speed generators are a possibility, but variable speed units are expensive and/or unproved. Among the constant speed generator candidates for use are synchronous induction and permanent magnet types. The generator of choice is the synchronous unit for large aero generator systems because it is very versatile and has an expensive data base. Other electrical components and systems are, however, under development.

Many combinations are possible in terms of the control system and may involve the following components:

- (1)Sensor – mechanical, electrical, or pneumatic:
- (2)Elements – relays, logic modules, analog circuits, a microprocessor, a fluidics, unit, or a mechanical unit; and
- (3)Actuators – hydraulic, electric or pneumatic.
- (4)A recommended combination of electronic transducers feeding into a micro-processor which, in turn, signals electrical actuators and provides protection.

CIRCUIT DIAGRAM

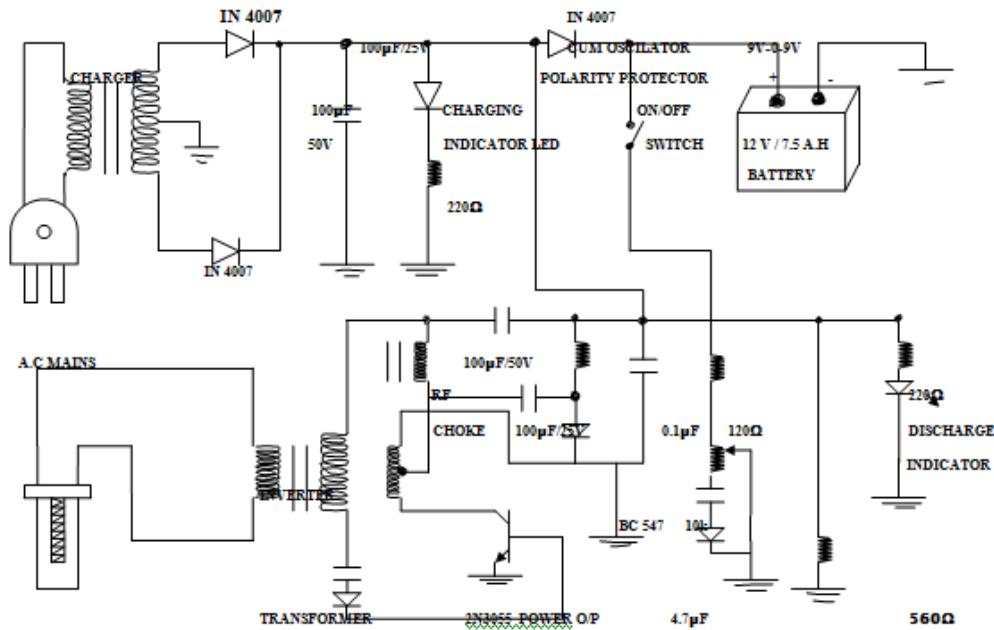

DESIGN OF CENTRIFUGAL PUMP:

The centrifugal pump has been designed for the work done by the impeller on water per second per unit weight of the water.

As the water enters the impeller radially which means that, the absolute velocity of water at inlet is in the radial direction and hence angle $\alpha = 90$ degree and $V_{w1} = 0$. Therefore the equation is

$$= V_{w1} \times U_2 / g \quad \text{[Head per unit weight]}$$

Therefore work done by pump on water per second,

$$= W_g \times V_{w2} \times U_2$$

$$\text{Discharge } Q = \Pi \times D_1 \times B_1$$

HEAD OF THE PUMP:

The head of a centrifugal pump may be expressed in two ways,

- static head
- manometric head

static head is the net total vertical lift through which water is lifted by the pump.

Manometric head is defined as the head against which a centrifugal pump has to work.

$$H_m = \text{Work done per kg of water} - \text{impeller losses}$$

$$= (V_{w2} * U_2 / g) - \text{impeller losses}$$

$$H_m = h_s + h_{fs} + h_d + h_{fd} + (V_d^2/2g)$$

EFFICIENCIES OF A CENTRIFUGAL PUMP;

The efficiency of a centrifugal pump may be expressed in the following forms,

- Manometric efficiency
- Mechanical efficiency

- Overall efficiency

Manometric efficiency or hydraulic efficiency

$$\eta_{\text{mano or } \eta_{\text{hyd}}} = \frac{\text{manometric head}}{\text{energy supplied}}$$

by the Impeller/Kg of water

$$= \frac{H_m}{(V_{w_2} \times u_2 / g)}$$

$$= \frac{g \times H_m}{(V_{w_2} \times u_2)}$$

$$\eta_{\text{mech}} = \frac{\text{Energy available at the impeller}}{\text{energy supplied to the pump by the prime mover.}}$$

$$\begin{aligned} \eta_{\text{overall}} &= \frac{\text{Actual work done by the pump}}{\text{Energy Supplied to the pump by the prime mover.}} \\ &= \frac{(\rho \times g \times Q \times H_m)}{P} \\ &= \eta_{\text{mech}} \times \eta_{\text{hyd}} \end{aligned}$$

TOWERS:

Four types of supporting towers deserve consideration, these are:

- (1) The reinforced concrete tower,
- (2) The pole tower,
- (3) The built up steel- tube tower, and
- (4) The truss tower.

Among these, the truss tower is favored because it is proved and widely adaptable, cost is low, parts are readily available, it is readily transported, and it is potentially stiff. Shell-tube towers also have attractive features and may prove to be competitive with truss towers.

The type of the supporting structure and its height is related to cost and the transmission system incorporated. It is designed to withstand the wind load during gusts (even if they occur frequently and for very short periods). Horizontal axis wind turbines are mounted on towers so as to be above the level of turbulence and other ground – related effects. The minimum tower height for a small WECS is about 10m, and the maximum practical height is estimated to be roughly 60m.

The turbine may be located either upwind or downwind of the tower. In the upwind location (i.e. the wind encounters the turbine before reaching the tower), the wake of the passing rotor blades cause repeated changes in the wind forces on the tower.

LIST OF MATERIALS:

Sl. No.	Name of the Parts	Quantity	Materials
01.		3	GFRP
02.	structure	12 Feet	M.S
03.	y	1	lead-acid
04.	ator	1	aluminium
05.	g	2	Steel
06.	cting Wire	-	Cu
07.	ox	1	M.S
08.	e Plate	2	M.S
09.	Wheel	2	M.S

COST ESTIMATION:

	NAME OF THE PARTS	QUANTITY	MATERIALS	COST
1	GFRP BLADES	3	M.S.	5850.00
2	Frame structures	3feet	M.S.	1800.00
3	Battery	1	Lead acid	950.00
4	Generator	1	Aluminium	750.00
5	Bearings	2	Steel	350.00
6	Connecting wires	-	CU	150.00
7	Spur gears	2	M.S.	950.00
8	Inverter light load	1	M.S.	900.00
9	Shaft	1	M.S.	550.00
			TOTAL	12250.00

LABOUR COST;

LATHE, DRILLING, WELDING, GRINDING, POWER HACKSAW, GAS CUTTING:

Cost = 20% of Total cost

OVERHEAD CHARGES;

The overhead charges are arrived by “Manufacturing cost”

$$\begin{aligned}
 \text{Manufacturing Cost} &= \text{Material Cost} + \text{Labour cost} \\
 &= 12250.00 + 4375.00 \\
 &= 16625.00\text{rs}
 \end{aligned}$$

Overhead Charges =20% of the manufacturing cost

=3325.00rs

TOTAL COST;

Total cost =Material Cost + Labour cost + Overhead Charges

=12250.00 + 4375.00 + 3325.00

=19950rs

Total cost for this project} = 21000rs

CONCLUSION:

Thus we have developed a “**WIND MILL POWER GENERATION**” which helps to know how to achieve non-conventional power generation. The application of pneumatics produces smooth operation.

By using more techniques, they can be modified and developed according to the applications.

REFERENCE:

- JihoonJeong et al, Design optimization of a wind turbine blade to reduce the fluctuating unsteady aerodynamic load in turbulent wind , (Manuscript Received August 5, 2011; Revised October 9, 2011; Accepted December 1, 2011).
- Vaibhav R.Pannase1 et al Computational and Analytical Analysis for Maximum Deflection of 18-Bladed HAWT Wind Mill Blade e-ISSN: 2278-067X, p-ISSN: 2278-800X, www.ijerd.com Volume 7, Issue 8 (June 2013), PP. 33-36 33
- ARVIND SINGH RATHORE 1 et al , Aerodynamic Analyses of Horizontal Axis Wind Turbine By Different Blade Airfoil Using Computer Program, Vol. 2 Issue 1, Jan.2012, pp. 118-123.