

A New Linear Companding Transform to Reduce the PAPR in OFDM System under Rayleigh Distribution

Dr. Gopala Krishnan¹, Venkatesh Thota²

¹Professor, ²Assistant Professor, ^{1,2}Dept. of ECE

^{1,2}Siddhartha Institute of Technology and Sciences, Hyderabad, Telangana, India.

ABSTRACT

Large amplitude fluctuations cause serious issues in orthogonal frequency-division multiplexing (OFDM) signals, when a nonlinear power amplifier (NLPA) has been utilized. These large amplitude fluctuations are known as peak-to-average power ratio (PAPR), which is a major disadvantage of OFDM system. To resolve this issue, one must need to reduce these large amplitude fluctuations in order to achieve higher data rates and to improve system performance. A well-known method for reducing the PAPR is companding transform (CT). It doesn't have any restrictions on system parameters such as frame format, number of subcarriers and type of constellation used. Recently, a linear nonsymmetrical companding transform (LNST) has been proposed which has a superior performance than the transformations based on logarithmic transforms such as μ -law companding. Here, a new linear companding transform (LCT) with Rayleigh distribution (RD) has been implemented with more design flexibility than LNST by introducing two inflexion points. Experimental results show that the proposed transform has a better PAPR reduction and bit error rate (BER) performance than LNST with better power spectral density (PSD).

Keywords: OFDM, Power Amplifiers, PAPR, Companding, LNST, LCT, PSD, Rayleigh distribution and BER

I. INTRODUCTION

OFDM (orthogonal Frequency division multiplexing) is a multicarrier modulation scheme that partitions the approaching bit stream into parallel, bring down rate sub streams and transmits them over orthogonal subcarriers [1] and [2]. Therefore, the transfer speed of each subcarrier is much smaller than channel bandwidth data transfer capacity and henceforth each subcarrier will encounter generally a flat blur. It is a data transmission efficient modulation plot and has the benefit of relieving inter-symbol interference (ISI) in Frequency particular fading channels. Today, OFDM is utilized as a part of numerous wireless gauges, for example, terrestrial digital video broadcasting (DVB-T) [3], digital audio broadcasting (DAB-T) [4], and has been executed in wireless local area networks (WLANs) (IEEE 802.11a, ETSI Hiperlan2) [5] and [6], wireless metropolitan zone systems (IEEE 802.16d) [6] and [7]. The primary disadvantage of OFDM is its high peak-to-average power ratio (PAPR) which causes genuine corruption in execution when nonlinear power amplifier (PA) is utilized. This high PAPR strengths the transmit PA to have a huge input back off (IBO) keeping in mind the end goal to guarantee straight amplification of the flag, which significantly lessens the efficiency of the amplifier. Moreover, high PAPR requires high determination for the receiver analog to-digital converter (A/D). Since the dynamic scope of the flag is much bigger for high PAPR, a high-determination quantizer is required to lessen quantization error, which requires more bits and spots a many-sided quality and power trouble on the receiver front end. In the writing, numerous arrangements have been proposed to lessen PAPR, for example, block coding [8], selective mapping (SLM) [9], partial transmit succession (PTS) [10], tone reservation and infusion [11], [12] and [13]. In any case, the majority of these arrangements have limitations on framework parameters, for example, number of subcarriers, casing configuration, and heavenly body sort. Flag distortion arrangements, for example, section and companding can be utilized without confinement on the framework parameters however at the cost of expanded bit error rate (BER) and unearthly regrowth. Despite the fact that section performs exceptionally well with low modulation orders, cutting error turns out to be extremely significant with higher requests and genuinely corrupts execution, which makes companding more appropriate for high data rates applications. The utilization of μ - law companding as PAPR decrease plot for OFDM frameworks was firstly examined in [14], where the creators displayed an exquisite hypothetical execution investigation of companded OFDM signals. Notwithstanding, their work just considered the effect of quantization commotion and disregarded PA nonlinearity. Later a general companding change was proposed, where the execution of four run of the mill companding plans; linear symmetrical transform (LST), linear nonsymmetrical transform (LNST), nonlinear symmetrical transform (NLST), and nonlinear nonsymmetrical transform (NLNST), were explored. It was demonstrated that, LNST is the best among the proposed companding plans regarding PAPR lessening and BER. These execution increases were accomplished by presenting an inflexion point in LNST so that little and huge flag

amplitudes could be treated with various scales. This permits more flexibility and opportunity in companding configuration to meet the framework necessities, for example, PAPR lessening, required flag average power, Power amplifier attributes, and BER. Notwithstanding, when the information flag goes through the inflexion limit, changed flag will have sudden hop that debases the power spectraldensity (PSD) of changed flag. Later on the creators proposed a straight change that has balanced mapping between the info and the yield changed signals. The companding structure was planned so that the yield flag has no unexpected hops, which brought about a superior PSD. In any case, its PAPR diminishment ability and BER execution are lower than LNST. Besides, the effect of PA nonlinearity was disregarded. In this paper, another linear companding transform (LCT) is proposed; the proposed change has two inflexion focuses to give more outline flexibility. The execution of the proposed change and LNST is assessed in Rayleigh channel with the nearness of nonlinear amplification by method for PC reproductions Results demonstrate that the proposed change has a superior PAPR decrease ability and BER execution than LNST with an improved PSD.

II. LITERATURE REVIEW

PAPR reduction methods have been considered for a long time and huge number of techniques has been produced. These strategies are talked about underneath:

A. Clipping

Clipping actually happens in the transmitter if power back-off is insufficient. Cutting prompts to a section commotion and out-of-band radiation. Separating in the wake of section can decrease out-of-band radiation, yet in the meantime it can bring about "peak regrowth". Rehashed cutting and separating can be connected to diminish peak regrowth in cost of many-sided quality. A few techniques for moderation of the section commotion at the receiver were proposed: for instance, recreating of the cut specimen, in light of other examples in the oversampled flag [15].

B. Coding

Coding techniques incorporate Golay complementary arrangements, block coding plan, complementary block codes (CBC), altered complementary block codes (MCBC) and so forth. A use of the Golay Complementary successions is constrained by the way that they cannot be utilized with M-QAM modulation. Straightforward plan, proposed in, depends on query tables containing groupings with lower PAPR. This technique doesn't endeavor to use those groupings for error redress/identification. CBC uses supplement bits that are built from the subset of the data bits. MCBC is an alteration of CBC appropriate for vast number of sub-carriers. Coding strategies have low multifaceted nature however PAPR diminishment is accomplished in cost of excess creating data rate misfortune.

C. Partial Transmit Sequences (PTS)

An arrangement of sub-carriers of an OFDM symbol is separated into non-covering sub-blocks [4]. Every sub-block experiences zero-cushioning and IDFT bringing about $p(k)$, $k=1 \dots V$, called PTS. Peak esteem advancement is performed over straight mix of PTSs: $\sum_{k=1}^V p(k)b(k)$, where $b(k)$ is streamlining parameter. The advancement parameter is frequently constrained to four turn factors: $b(k) \in \{\pm 1 \pm j\}$

D. Selected mapping (SLM)

An arrangement of sub-carriers of an OFDM symbol is increased sub-carrier astute by U revolution vectors b . Then all the turned U data blocks are changed into the time-area by IDFT and after that the vector with the most reduced PAPR is chosen for transmission.

E. Interleaving

The same data block is interleaved by K different interleavers. K IDFTs of the original data block and modified data blocks are calculated. PAPR of K blocks is calculated. The block with minimum PAPR is transmitted.

F. Tone Reservation (TR)

L sub-carriers are reserved for peak reduction purposes. The values of the signals to insert on peak reduction sub-carriers are computed by suitable Linear programming algorithm.

G. Tone Injection (TI)

TI maps one constellation point of the original constellation (for example QPSK) to several constellation points of the expanded constellation (for example 16QAM). PAPR redaction is achieved by choosing constellation points of the expanded constellation.

H. Active Constellation Extension (ACE)

ACE modifies original constellation by moving nominal constellation points located on the outer constellation boundaries in the directions that don't decrease Euclidean distances between constellation points [16], [17], [18] and [19].

I. Nonlinear Companding Transform (NCT)

It compands the original OFDM signal using strict monotone increasing function. Companded signal can be recovered by the inverse function at the receiver [20].

III. PROPOSED FRAME WORK

A companding system compresses the signal at input and expands the signal at output in order to keep the signal level above the noise level during processing. In other words, companding amplifies small inputs so that the signal level is well above the Noise floor during processing. At the output, the original input signal is then restored by a simple attenuation. Companding increases the SNR when the input signal is low and therefore reduces the effect of a system’s noise source. Fig shows a typical companded OFDM system, where input bit stream is first converted into parallel lower rate bit streams and then fed into symbol mapping to obtain symbols $S_k = S_0, S_1, \dots, S_{N-1}$. These symbols are then applied to IFFT to generate OFDM symbol, which can be expressed as

$$x(n) = \frac{1}{\sqrt{N}} \sum_{k=0}^{N-1} S_k e^{j\frac{2\pi kn}{N}} \quad n = 0, 1, \dots, N - 1$$

The PAPR of discrete OFDM signal may be expressed as

$$PAPR = \frac{\max_t [|x(t)|^2]}{\frac{1}{T} \int_0^T |x(t)|^2 dt} \quad (1)$$

If OFDM signal is oversampled by a factor ≥ 4 , its PAPR is a good approximate to the one of continuous OFDM signal. Oversampling by a factor of L can be achieved by padding the symbols S_k with $(L-1)*N$ zeros. After IFFT, the resultant symbols are converted to serial and companding transform (CT) is performed. To guarantee that all transformed signals are under a given threshold, a digital clipping “not shown in Fig. 1” is used after the CT. Note that, due to the disadvantages of clipping, the CT should be designed cautiously so that the amount of clipped signals is as little as possible. A cyclic prefix (CP) is then inserted to OFDM symbol interval to eliminate inter symbol interference (ISI). It was shown in that, a linear companding transform with an inflexion point (LNST) can outperform logarithmic-based companding transforms such as μ -law companding.

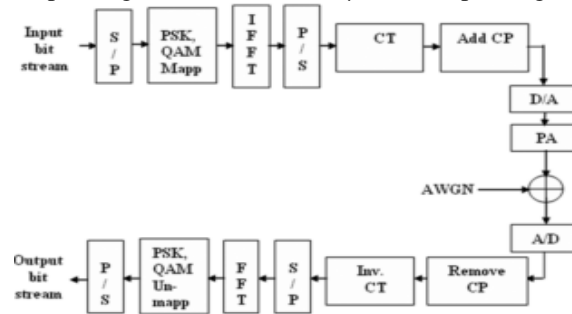

Fig.1 Block diagram of companded OFDM system

LNST can be expressed as

$$y(n) = \begin{cases} \frac{1}{\alpha} \cdot x(n) & |x(n)| \leq \beta \\ \alpha \cdot x(n) & |x(n)| > \beta \end{cases} \quad (2)$$

Where $0 \leq \alpha \leq 1$, and $0 \leq \beta \leq \max\{|x(n)|\}$. Since $x(n)$ is complex-valued, the companding transform should be applied to real and imaginary parts separately. At receiver, the original signal can be recovered according to

$$\tilde{x}(n) = \begin{cases} \alpha R(n) & n \in \varphi_1(\beta) \\ \frac{1}{\alpha} R(n) & n \in \varphi_2(\beta) \end{cases} \quad (3)$$

$$R(n) = y(n) + w(n) + q(n)$$

$$\varphi_1(\beta) = \{n \mid |x(n)| \leq \beta\}$$

$$\varphi_2(\beta) = \{n \mid |x(n)| > \beta\}$$

Where $w(n)$ is $q(n)$ noise component, is quantization noise which is usually very small, $\varphi_1(\beta)$ and $\varphi_2(\beta)$ are the index sets of OFDM samples. It assumed that the receiver has the knowledge of the two sets. It is clear that due to the presence of the inflexion point β , small and large parts of the signal can be treated with different scales; enlarging small amplitudes by $1/\alpha$ while compressing large amplitudes α by, which gives more flexibility and freedom in designing the companding form in order to meet the given system requirements such as PAPR reduction, signal average power, Power amplifier characteristics, and BER, and hence, leads to a better performance. However, taking into account the more accurate case that OFDM signal consists of three parts: small amplitudes, large

amplitudes, and average amplitudes, more design flexibility and performance enhancement can be achieved if each one of these parts treated independently with a different scale. To satisfy this, a new linear companding transform (LCT) with two inflexion points is proposed, the new transform is

$$y(n) = \begin{cases} \alpha_1 \cdot x(n) & |x(n)| \leq \beta_1 \\ \alpha_2 \cdot x(n) & \beta_1 < |x(n)| \leq \beta_2 \\ \alpha_3 \cdot x(n) & |x(n)| > \beta_2 \end{cases} \quad (4)$$

$$\tilde{x}(n) = \begin{cases} \frac{1}{\alpha_1} \cdot R(n) & n \in \varphi_1(\beta_1) \\ \frac{1}{\alpha_2} \cdot R(n) & n \in \varphi_2(\beta_{1,2}) \\ \frac{1}{\alpha_3} \cdot R(n) & n \in \varphi_3(\beta_2) \end{cases} \quad (5)$$

$$\begin{aligned} R(n) &= y(n) + w(n) + q(n) \\ \varphi_1(\beta_1) &= \{n \forall |x(n)| \leq \beta_1\} \\ \varphi_2(\beta_{1,2}) &= \{\beta_1 < n \forall |x(n)| \leq \beta_2\} \\ \varphi_3(\beta_2) &= \{n \forall |x(n)| > \beta_2\} \end{aligned}$$

Where $\alpha_1 > 1$ and $\alpha_2 < 2$, regarding α_2 , setting its esteem to solidarity can effectively diminish the undesired effect of commotion change at the receiver since average amplitudes are scaled with solidarity and subsequently, no converse scaling is required at the receiver. Figure 2 demonstrates profiles of both transforms where $A = \max\{|x(n)|\}$, obviously with two inflexion focuses, more outline flexibility is accessible and consequently a superior tradeoff amongst PAPR and BER can be accomplished.

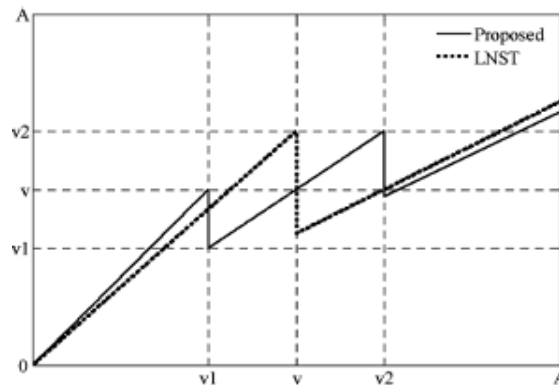

Fig.2 Profiles of companding transforms

Figure 3 demonstrates the first and companded OFDM signals on the perplexing plane, were trans-structures are intended to protect the average power of information flag for contextual analysis, for handy reason, the average power of companded flag ought to be chosen to best fit for specific PA qualities incorporated into the framework. The fluctuation of changed clamor at the receiver alongside the average power of companded flag, clearly the companded motion by proposed LCT has the least PAPR "littlest span," since LCT takes into account more decrease of PAPR by additional pressure of substantial amplitudes and by additional growth of little amplitudes without influencing average amplitudes and subsequently, reallocate power among all subcarriers. In addition, the flexibility of the proposed change permits diminishing unexpected hops in the changed flag, which prompts to better power range as portrayed in Figure 5. Since the receiver must have the learning of record sets, side information ought to be transmitted alongside the flag. For LNST either or can be transmitted as side information on committed subcarriers or imbedded in preparing successions. Specifically if is set to be equivalent to the square foundation of flag average power, then transmitting will bring about less overhead to be transmitted since it contains a littler number of lists. This is on account of the specimens of vast amplitudes are generally happening with low likelihood. With respect to proposed change, favorable circumstances of the additional inflexion point come at the cost of another record set that ought to be transmitted.

Rayleigh fading is a rational model, when an environment that consists of many objects can scatter the transmitted signal before the arrival of signal at receiver. The central limit theorem holds that, the channel impulse response can be modeled well as a gaussian process irrespective of individual components distribution when there are enough much scatter [21]. When we apply Central Limit Theorem (CLT) to the large number of paths, then each path can be modeled with time as the variable as circularly symmetric complex Gaussian random variable (GRV), which is known as Rayleigh channel model [22]. When there is no prevalent component to the scatter such model will have

the mean of zero and the phase between 0 and 2π radians. Therefore the channel response envelope is Rayleigh distributed. A circularly symmetric complex GRV is of the form,

$$Z = X + ij \tag{6}$$

where the real and imaginary parts are zero mean i.i.d. GRV's.

For circularly symmetric complex random variable,

$$E[Z] = E[e^{j\theta}Z] = e^{j\theta}[Z] \tag{7}$$

A circularly symmetric complex GRV is completely specified by the variance

$$\sigma^2 = E[Z^2] \tag{8}$$

The magnitude $|Z|$, which has the PDF of $\phi(z)$, is called as Rayleigh random variable

$$\phi(z) = \frac{z}{\sigma^2} e^{-\frac{z}{2\sigma^2}}, z > 0 \tag{9}$$

IV. SIMULATION RESULTS

Experimental results have been done in MATLAB tool. Here 400 symbols have been considered with 512 point FFT and 64 subcarriers. Input data that have been transmitted to test the performance of proposed and conventional PAPR reduction schemes is 400×64 i.e., serially 25,600 bits. Table 1 show that the simulation parameters considered for executing the PAPR reduction in OFDM system.

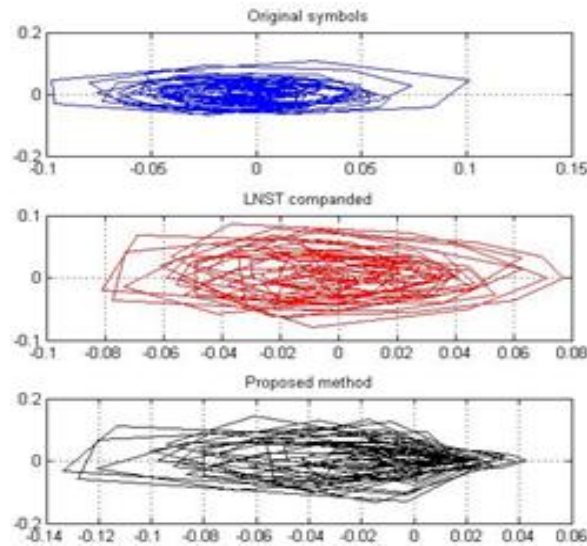

Fig.3 Companded signals using original, LNST and proposed schemes

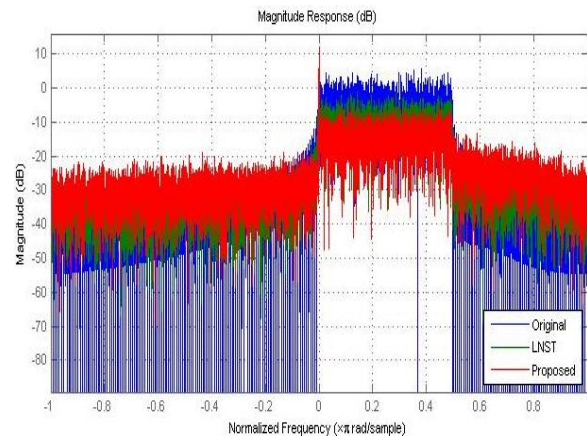

Fig.4 Power Spectrum magnitude response

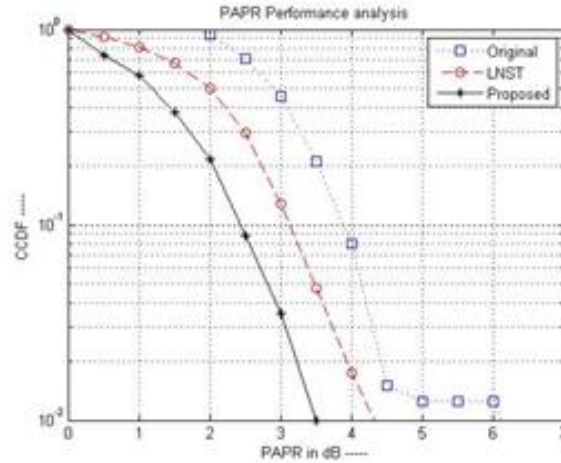

Fig.5 Performance analysis PAPR reduction

Figure 3 (a), (b) and (c) shown that the companded signal of original, existing and proposed algorithms. Power spectrum magnitude response of proposed and conventional schemes has been shown in figure 4. Non-linearities reduction in OFDM has been compared in figure 5 by reducing the PAPR using proposed and conventional schemes.

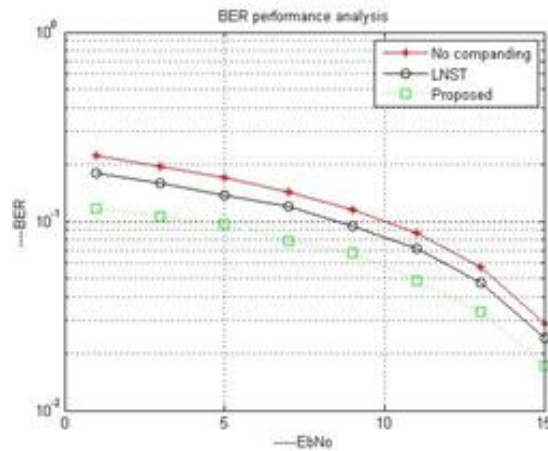

Fig.6 Performance analysis BER with AWGN

BER performance of proposed and conventional schemes has been shown in figure 6 and 7 respectively. We can observe that the proposed Rayleigh distribution has performed superior to the proposed AWGN.

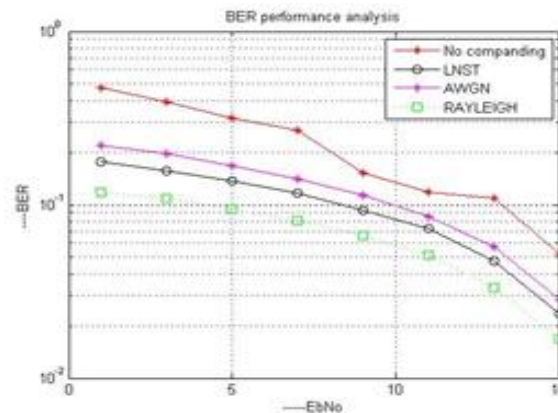

Fig.7 Performance analysis BER with AWGN and Rayleigh distribution

Table I
Simulation parameters

Parameters	Specifications
No. of Symbols	400
FFT & IFFT size	512
No. of Subcarriers	64
Channel model	AWGN and Rayleigh
Modulation scheme	QPSK
Constellation points	M=4
Inflexion point α	0.825
α_1, α_2 and α_3	2, 1 and 0.45
β_1 and β_2	20% of A and 40% of A

V. CONCLUSIONS

A new linear companding transform with Rayleigh distribution has been proposed with two inflexion points to enhance the companding design flexibility. Simulation results show that the proposed method reduces the PAPR with better BER performance than conventional PAPR reduction schemes, with less spectral broadening. In general, with the assistance of two inflexion points, we can scale the different signal levels independently. Hence, the proposed transform has met requirements of the system, characteristics of power amplifier, and also achieved an excellent tradeoff between PAPR reduction and BER performance.

REFERENCES

1. Wu Y., W. Y. Zou, "Orthogonal frequency division multiplexing: A multi-carrier modulation scheme," IEEE Transactions on Consumer Electronics, vol. 41, no. 3, pp.392–399, Aug. 1995.
2. Van Nee R., Prasad R., OFDM for wireless Multimedia Communications, Artech House, 2003.
3. ETSI, "Digital Video Broadcasting (DVB); Framing structure, channel coding and modulation for digital terrestrial television", European Telecommunication Standard, Standard EN-300-744, 2004-2006.
4. ETSI, "Radio broadcasting systems; Digital Audio Broadcasting (DAB) to mobile, portable and fixed receivers", European Telecommunication Standard, Standard EN-300401, May 1997.
5. Hiperlan2, "Broadband Radio Access Networks (BRAN), HIPERLAN Type 2; Physical (PHY) layer", ETSI, Tech. Rep., 1999.
6. Part 16: Air Interface for Fixed Broadband Wireless Access Systems Amendment 2: "Medium Access Control Modifications and Additional Physical Layer Specifications for 2-11 GHz", IEEE, Standard IEEE Std. 802.16a-2003, 2003.
7. Part 16: Air interface for fixed broadband wireless access systems. "Amendment for physical and medium access control layers for combined fixed and mobile operation in licensed bands," IEEE, Standard IEEE Std 802.16e/D12, October 2005.
8. A. E. Jones and T. A. Wilkinson "Block coding scheme for reduction of peak to mean envelope power ratio of multicarrier transmission schemes", IEE Elect. Lett., vol. 30, pp.2098 -2099, march 1994

9. Sang Woo Kim, Heui Seop Byeon, Jin Kwan Kim, Heung-Gyoon Ryu, "An SLM Based Real Time PAPR Reduction Method Using Dummy Sequence Insertion in OFDM Communication", *Fifth International conference on Information, Communication and Signal Processing*, pp. 258-262, Dec 2005.
10. Luo, R.Z., Li, R., Wu, X.Q., Hu, S.N. and Niu, N. "A PTS Optimization Scheme with Superimposed Training for PAPR Reduction in OFDM System". *Communications and Network*, **6**, 97-104, Feb 2014.
11. T. Wattanasuwakull, W. Benjapolakul, "PAPR Reduction for OFDM Transmission by using a method of Tone Reservation and Tone Injection" *Fifth International Conference on Information, Communications and Signal Processing*, ISBN: 0-7803-9283-3, pp. 273-277, 2005.
12. Malhar Chauhan, Prof.Abhishek Chobey, "PAPR Reduction in OFDM System Using Tone Reservation Technique", *International Journal of Computer Technology and Electronics Engineering (IJCTEE)*, Volume 2, Issue 4, August 2012.
13. Malhar Chauhan, Prof.Abhishek Chobey, "PAPR Reduction in OFDM System Using Tone Reservation Technique", *International Journal of Computer Technology and Electronics Engineering (IJCTEE)*, Volume 2, Issue 4, August 2012.
14. X. Wang, T.T. Thung, and C.S. Ng, "Reduction of Peak-to Average Power Ratio of OFDM System Using a Companding Technique", *IEEE. Trans. On Broadcasting*, Vol.45, No.3, pp.303-307, Sep.1999.
15. X. Li and L. J. Cimini, "Effect of clipping and filtering on the performance of OFDM," *Proc. IEEE VTC '97*, pp. 1634-1638, 1997.
16. Eugen-Victor Cuteanu, Alexandru Isar, "PAPR Reduction of OFDM Signals using Active Constellation Extension and Tone Reservation Hybrid Scheme", *The 8th Advanced International Conference on Telecommunications (AICT)*,pp. 156-163, 2012
17. M. Niranjana, S. Srikanth, "Adaptive Active Constellation Extension for PAPR Reduction in OFDM Systems", *International Conference on Recent Trends in Information Technology (ICRTIT)*,pp. 1186-1189, June 2011.
18. Madhuri. P, Dr. Malleshwari B L, "Peak to Average Power Ratio reduction by CB-ACE and Adaptive ACE algorithms", *International Journal of Emerging Technology and Advanced Engineering*, Vol.2, Feb 2012.
19. L. Wang and C. Tellambura, "An adaptive-scaling algorithm for OFDM PAR reduction using active constellation extension," in *Proc. IEEE Vehicular Technology Conf.*, Sep. 2006, pp. 1-5.
20. Yuan Jiang. *New companding transform for PAPR reduction in OFDM*. *IEEE Communications Letters*. 2013; 14(4):282-284.
21. Robertson, P.; Kaiser, S. "The effects of Doppler spreads in OFDM (A) mobile radio systems", *Vehicular Technology Conference*, 1999. VTC 1999 - Fall. IEEE VTS.
22. Bernard Sklar (July 1997). "Rayleigh Fading Channels in Mobile Digital Communication Systems Part I: Characterization". *IEEE Communications Magazine* 35 (7): 90-100.