

A model for reliable forecasting of supply chain demand with a neural network approach

Mehdi Safaei

^aDepartment of Industrial Engineering, Istanbul Gelisim University, 34215, Avcilar, Istanbul, Turkey

Abstract

Demand forecasting has always been a challenging issue in the supply chain. For this reason, it is known as the main tool for success in balancing supply and demand. There are many methods, such as regression, time series for prediction. If causal relationships between the influential factors of the model are not clear, all of these methods will lose their accuracy. On the other hand, considering all causal relationships, despite increasing the accuracy of the model, makes it an NP-Hard model. If the demand for several customers is considered, solving this model will be more difficult and sometimes impossible. In this paper, using a combination of several artificial neural networks such as Principal Component Analysis, Self-Organization Map, and Multi-Layer Perceptron network, a sustainable hybrid model is presented. The purpose of this model is to provide a solution to overcome this challenge by giving a reliable forecast for demand, with acceptable accuracy. The results of this study all testify to the validity of this claim.

Keywords: Artificial neural networks; Supply chain management; Forecast; Hybrid model.

1. Introduction

Today, due to the significant growth of overseas outsourcing activities and the high diversity of products, companies and industrial units are forced to use forecasting methods to predict pre-occurrence demand. Higher accuracy predicts a higher balance between supply and demand. This maximizes supply chain profits and minimizes bullwhip effects. On the other hand, intense market competition does not allow companies to spend a lot of time predicting consumption.

Due to the increasing complexity of markets and their rapid movement towards globalization, the number of factors affecting the amount of demand from customers is increasing day by day. This has led to predictions being made only by involving a limited number of factors that have a significant impact on the rate of forecasting so that the cost and time of forecasting are reasonable. However, identifying these factors is not always easy.

Uncertainty in demand is an unforgivable fact that can be cited as the most important factor in predicting error. Many approaches can be used to reduce the uncertainty effect of demand and thus improve the performance of supply chain forecasting or a company. An attractive approach that is referred to as an effective approach is the demand aggregation approach [1], this aggregation can take place over time or customer.

Artificial neural networks are one of the meta-heuristics algorithms that have been around for about six decades, and by modeling the human neural network, they provide us with the ability to solve a wide range of problems in a reasonable amount of time. Among the most important issues that these solution algorithms can solve in a reasonable time efficiently, we can mention the issues of function fit, categorization, time series, Principal Component selection, and so on.

Principal Component Analysis: PCA, Self Organization Map: SOM and Multi-Layer Perceptron: MLP, each used to identify the most important factors, categorize data, and fit the best function on a data set Process.

In this paper, an attempt has been made to provide a hybrid model by combining three artificial neural networks, SOM, PCA, and MLP. Its use is to provide a reliable forecast for supply chain demand. It can make accurate predictions when there are a large number of customers and there are many complex causal relationships. So that even if these causal relationships are unclear, it is still possible to make appropriate predictions in a short time and effectively.

In the continuation of this article, the following sections will be discussed in order. In the following section, there is a literature review for this study. Section 3 defines the problem and the assumptions and solves the simulated problem. In Section 3, the results and future suggestions for further research are presented below.

2. Literature Review

Rosenblatt (1958), after presenting Hebbian's Law Learning, provided a basic structure for the perceptron artificial neural network (MLP) and explained how information is stored and how it affects network behavior [2].

Carbonneau (2008) provided a rudimentary structure for the artificial neural network of self-organizing maps (SOMs) modeled on the structure of the human brain [3]

LIU et al. (2008) used a backup vector machine and neural networks to predict demand for a simulated supply chain and used real casting orders in Canada. They then compared this method with other traditional methods such as moving average, linear regression, etc. [4].

One year later, Huang used the PCA artificial neural network to remove the overlap between data related to the distribution of high-power electronics and showed that the use of the artificial neural network PCA before the MLP network performed better than the state of the network. PCA is not used [5].

In 2011, Ismail et al. Made an accurate prediction of future demand for a specific range of products with very volatile and correlated demand using Monte Carlo simulation [6].

In another study in 2015, a SOM hybrid model and a minimum square error support vector machine were used to approximate predictive time series [7].

In 2016, Chong et al. Used data mining techniques to identify customer segments with similar demand behavior [8].

In 2018, Aguayo and Barreto used MLP to predict online product sales [9]

Akdeniz et al., By carefully studying the structure of the neural network SOM, used it to form a comprehensive assessment for time series and presented a new structure by reviewing the previous structure [10].

In 2018, Hess used the technique of self-integrating moving average and neural networks (Pi-Signa) to approximate predictive time series [11].

Rostami-Tabar examined the basics of PCA [1]. They used a moving average self-regression model and aggregated data over time to increase predictability.

According to research, there has been no research study that has used the selection of key factors by the PCA network and the aggregation of customers by the SOM network together. In the following, an attempt has been made to remove this research gap by presenting the framework and hybrid model.

3. Model and Simulation

In precise forecasting methods, it is always necessary to have information about the relationship between the influencing factor and the predictable factor. On the other hand, if the number of influential factors increases, the prediction methods lose their effectiveness. Furthermore, if multiple customers are considered, these practices effectively lose the ability to solve the problem.

The predictive issues that exist today are made up of a large number of influential factors, and the relationship between these influential factors and the predictive factor is unclear. On the other hand, the multiplicity of customers has greatly increased the volume and complexity of the problem, so that accurate methods are not effective in solving such problems. For example, the simulation problem that follows is a data set of 107 customers whose effective factors are discussed in 9 columns for 39 periods. The relationship between any of the factors influencing the predictable variable is not clear, but the impact of these factors on it is clear. Although accurate prediction methods such as multiple regression provide us with an accurate answer, it is necessary to determine the relationship between the affected and predicted variables. So this makes it possible to make a reliable prediction by accepting the minimum error.

Considering a large number of factors, although it better identifies the position of the data, the factors by which the data are not a highly variable, cause overlap between the data. This disrupts the categorization and prediction process. In the following article, a structure is introduced to identify and eliminate the factors on which the data have little variability. After deleting the data, group it, and predict a group of customers instead of for each customer.

3.1. Model Assumptions

To use this hybrid model, the data must have features that are presented in the form of multiple assumptions.

1. Data can only take positive values because the data set needs to be added together to determine the amount of data that is only in one group; Given that data is the value of using a resource, this is the case in most real-world issues.
2. The factors affecting the variable in the forecast are clear but the type of relationship between them is unclear. In many real-world problems, there is a state where the effect of the variable is known, but how it is affected is unclear.

3. There is a sharp overlap between the studied data. If there is no overlap, the PCA network application on the data will not be necessary. Because the specific values of the data are usually in a range, this indicates the variability of the data on all dimensions of the data.
4. Data on all demand points are available in equal numbers. Data categorization requires that the data for all customers be in the same period. Otherwise, it is not possible to categorize the data.
5. The amount of the predictive factor is such that it is possible to predict it for a group of customers.

3.2. Artificial neural networks in the model

In this paper, three artificial neural networks such as Principal Component Analysis: PCA, Self-Organization Map: SOM, and Multi-Layer Perceptron: MLP have been used. In the following, the concepts related to these three networks will be briefly reviewed.

The artificial neural network PCA is a network that uses the analysis of values and specific vectors related to each of the influential factors to identify the factors on which the data has the most changes.

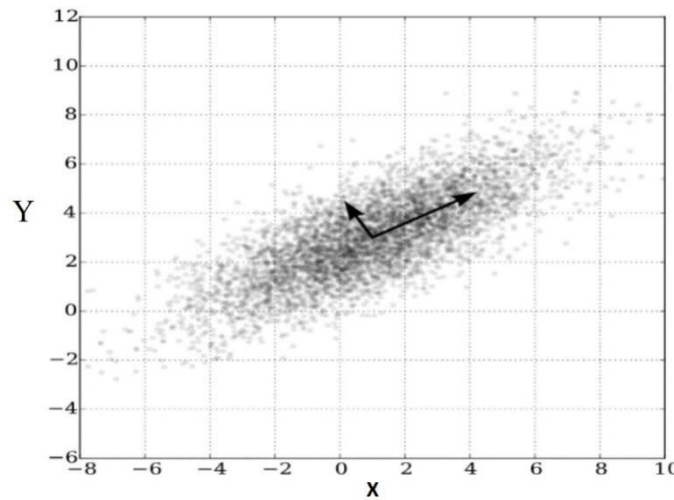

Figure 1 A custom two-dimensional data space

As can be seen in Figure 1, the specific value of the data in terms of dimension X is greater than the specific value of data in terms of dimension Y. If the data is depicted on these dimensions, it becomes clear that the variability of the data on the X dimension is greater than the variability of the data on the Y dimension. By using this network, the dimensions of the data can be reduced desirably without much change in quality. The collective distribution function is used to decide on the number of dimensions to be removed. This means that the quality of the data is not less than a certain level.

The SOM is one of the classified networks that can categorize data in an uncontrolled manner. The network's algorithm is modeled on the neural network of the human brain and works by taking the number of groups that are expected to be classified as a parameter, according to which it forms a network of neurons. The learning algorithm puts the neural network in the data space in specific steps so that all the data are in the specified categories (See Figure 1) [12].

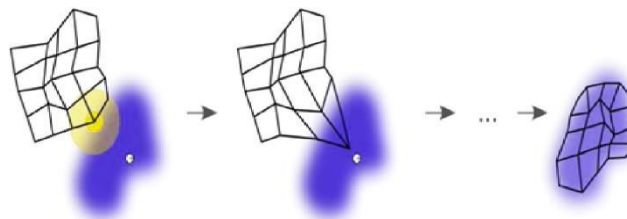

Figure 2 Symbolic schematic of repetition of SOM algorithm execution

The MLP network is one of the neural networks that allow you to fit the function on a set of data. The procedure is that they receive the number of neurons and the number of layers of the network as parameters. Subsequently, given the learning function provided to the network, the network begins to approximate the function that holds the data according to the existing stop conditions [13].

For example, a two-layer perceptron network with two neurons in the first layer and one neuron in the second layer is as follows schematically:

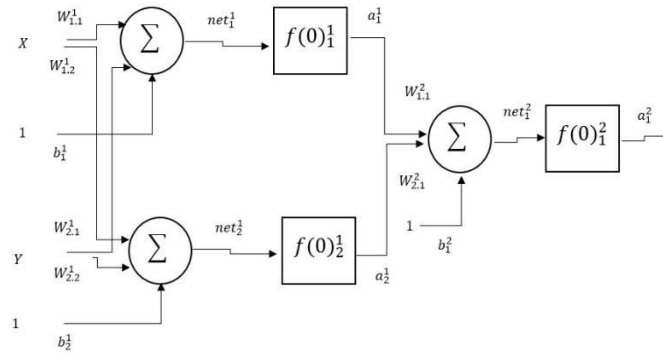

Figure 3 Schematic of a two-layer perceptron network

Components:

$i: \{1,2\}$, $j: \{1,2\}$ and $k: \{1,2\}$

X and Y: Equivalent to input data or matrix of input data.

$W_{i,j}^k$: Weight is given to data i, input to neuron j and in layer k

b_j^k : Bias for neurons j in layer k

Σ : Plus sign

net_j^k : The sum of the input sentences to neuron j in layer k

$f(0)_j^k$: The output of neuron j in layer k

a_j^k : Neuron j transfer function in layer k

In fact, any neuron in the layers of the neural network of the perceptron can be described by a mathematical formula ($N = F(\sum_{i=0}^R W_i \times X_i)$), and each network layer can be considered equivalent to space change.

The Persephone network divides the input data into three parts, and these data are provided to the network in three phases: Training, Validation, and Testing.

In the Training phase, the values of the influential factors in each period (Inputs) and the variable values in the corresponding prediction of that period (Targets) are provided to the network so that the network can approximate the relationship between them.

In the Validation phase, the values of the influential factors are provided to the network. Then, the network is asked to predict the amount of the variable in progress according to the initial relationship that the network has obtained from applying the values in the Training phase. But after the prediction, the "real value" is also given to the network and the network is allowed to improve the approximation function.

In the Testing phase, like the Validation phase, the values of the influential factors specified for this phase are provided to the network. At the same time, the network is asked to predict the amount in proportion to those values. But the network is no longer allowed to change the relationship that the network has gained from the data.

3.3. Proposed structure and its implementation

According to the explanations given in Section 3-2 about the three artificial neural networks PCA, SOM network and MLP network, a framework consisting of these three networks can be formed as follows:

First, PCA is applied to the data to identify the dimensions of the data on which the data is most variable. Then use a SOM network to classify the data into separate categories. Finally, to predict the amount of demand for each category of data, a schematic of this proposed framework is shown in Figure 4.

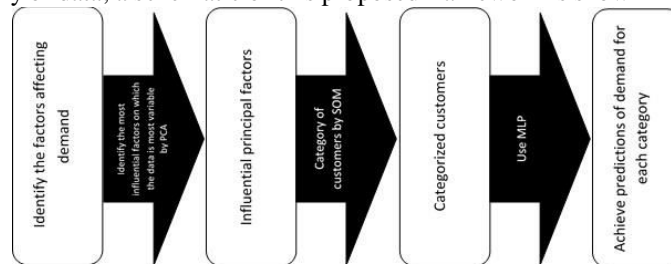

Figure 4 A schematic of the proposed framework implementation

With the intention of applying the PCA network to the data, the data related to each customer in different periods are placed on the rows of the table so that it is possible to calculate the special data vector for special

data, the number of which is equal to the data dimensions. After determining the dimensions on which the data has the most variability, remove the relevant dimensions, which results in a reduction in the volume of data.

Then, the data related to each customer is placed on a line so that when applying the SOM network for data classification, similar components such as data are compared and customers have the same number of dimensions in the data space. Finally, according to the classification that the SOM network has performed on the data, similar components such as the data in a package are added. The MLP network is then applied to each category to predict the amount of period or subsequent periods for each data category. The following is a numerical result of applying this structure to a simulated data set.

3.4. Simulation Case

To validate the proposed framework, a real data set was included, which included 9 influential factors in 39 periods. For this purpose, the distribution of effective factors was identified by the software (Easy Fit), and 4134 random numbers were generated from each distribution. Given that the value of each random number generated must be positive, another random number was placed instead of the negative random number. In the end, the amount of factor to be predicted was obtained by a random relationship that also considered the covariance between the influential factors.

Then, the proposed framework in MATLAB software was coded. According to the results of the PCA network, the specific values associated with the first and second factors are 193.13 and 669.88, respectively. Due to the significant difference between these values and the rest of them, it was decided to eliminate these two factors.

Then, the SOM network was applied to the data with two neurons. Data distribution is divided into two categories in Figure 5.

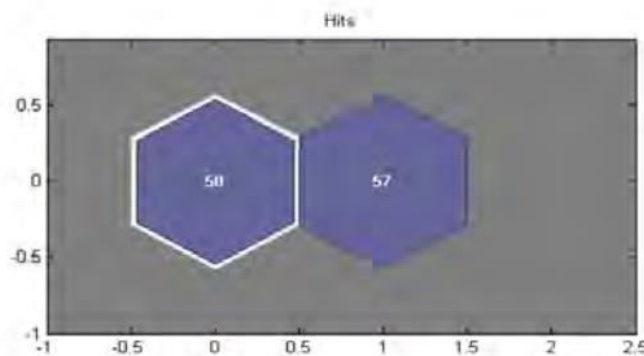

Figure 5 Histogram Distribution of samples

In later times, as the number of neurons increased, the network was categorized by placing only one sample in each category, indicating the ambiguity of the data; Thus, the allocation of two neurons is sufficient to classify this data set.

Then, in similar items, the samples in each category were added together, to sum up, 107 samples in two categories. In the last step, an MLP network was designed for each category. For training, each network provided 38-period data to the networks, and period 39 data was maintained for validation and sensitivity analysis.

4. Model Results and Validation

The MLP network designed for each category was applied with 1 to 30, 40, 60, and 100 neurons on each category. The result of the lowest relative error value of the prediction value for the data of Period 39 of each category is given in Table 1.

TABLE I Minimum relative error of network results

Number of neurons	Relative error			
	Category 1		Category 2	
	With PCA	Without PCA	With PCA	Without PCA
5		0.00064		
10	0.00034		0.00534	
18				0.00794

5. Conclusion and Future Studies

As can be seen in Table 1, the application of the PCA network, or more clearly the removal of dimensions from the data on which the data have high variability dimensions, does not lead to a decrease in predictive accuracy. Rather, with the right layout of a multilayer perceptron network (MLP), predictions can be made with higher accuracy.

Overall, the application of the proposed structure in this study helps to make the forecast more efficient and accurate. In line with this research, it is suggested that future research focus on algorithmic design in order to find the optimal number of dimensions that can be removed from the data. Therefore, besides, another neural network can be used for this purpose.

References

- [1] B. Rostami-Tabar, M. Babai, M. Ali and J. Boylan, "The impact of temporal aggregation on supply chains with ARMA(1,1) demand processes," *European Journal of Operational Research*, vol. 273, no. 3, p. 920–932, 2019.
- [2] T. Kohonen, "The self-organizing map," *Proceedings of the IEEE*, vol. 78, no. 9, p. 1464–1480, 1990.
- [3] R. Carbonneau, K. Laframboise and R. Vahidov, "Application of machine learning techniques for supply chain demand forecasting," *European Journal of Operational Research*, vol. 184, no. 3, p. 1140–1154, 2008.
- [4] J. LIU, Q. LIU and S. ZHU, "Ear recognition based on improved 2D principal component analysis and neural network," *Journal of Computer Applications*, vol. 29, no. 12, p. 3357–3359, 2010.
- [5] M. Huang, "Real options approach-based demand forecasting method for a range of products with highly volatile and correlated demand," *European Journal of Operational Research*, vol. 198, no. 3, pp. 867-877, 2009.
- [6] S. Ismail, A. Shabri and R. Samsudin, "A hybrid model of self organization map (SOM) and least square support vector machine (LSSVM) for time-series forecasting," *Expert Systems with Applications*, vol. 38, no. 8, pp. 10574-10578, 2011.
- [7] P. Murray, B. Agard and M. Barajas, "Forecasting Supply Chain Demand by Clustering Customers," *IFAC Papers OnLine*, vol. 48, no. 3, p. 1834–1839, 2015.
- [8] A. Chong, B. Li, E. Ngai, E. Chang and F. Lee, "Predicting online product sales via online reviews, sentiments, and promotion strategies," *International Journal of Operations & Production Management*, vol. 36, no. 4, p. 358–383, 2016.
- [9] L. Aguayo and G. Barreto, "Novelty Detection in Time Series Using Self-Organizing Neural Networks: A Comprehensive Evaluation," *Neural Processing Letters*, vol. 47, no. 1, p. 717–744, 2018.
- [10] E. Akdeniz, E. Egrioglu, E. Bas and U. Yolcu, "An ARMA Type Pi-Sigma Artificial Neural Network for Nonlinear Time Series Forecasting," *Journal of Artificial Intelligence and Soft Computing Research*, vol. 8, no. 2, p. 121–132, 2018.
- [11] A. Hess and J. Hess, "Principal component analysis," *Transfusion*, vol. 58, no. 7, pp. 1580–1582," *Transfusion*, vol. 58, no. 7, p. 1580–1582, 2018.
- [12] S. Kia, *Neural network in matlab*, Tehran: Kiyay Rayan Sabz, 2016.
- [13] A. Klepaczko, M. Strzelecki, M. Kociolek, E. Eikefjord and A. Lundervold, "A Multi-Layer Perceptron Network for Perfusion Parameter Estimation in DCE-MRI Studies of the Healthy Kidney," *Applied Sciences*, vol. 10, no. 5525, pp. 1-22, 2020.